



ARAS

KABLO

Where Energy Meets Reliability

CATALOGUE

KATALOG

Mission

To contribute the increase the export of the country, keeping the satisfaction of its employees and customers at the top level with the ever-growing experienced staff while transforming the technology into trust in energy cable production in a way that is sensitive to quality, environment and human health.

Vision

In line with the rules of scale economics, to advance the position of ARAS KABLO without compromising the principles of the sector innovator.

Misyon

Sürekli gelişen teknolojisini, enerji kablosu üretiminde kalite, çevre ve insan sağlığına duyarlı bir biçimde güvene dönüştürürken, sürekli büyüyen tecrübeli kadrosuyla, çalışanlarının ve müşterilerinin memnuniyetini en üst seviyede tutup, ülke ihracatına olan katkısını arttırmak.

Vizyon

ARAS KABLO'yu sektörün yenilikçisi yapan prensiplerinden taviz vermeden, ölçek ekonomisinin kuralları doğrultusunda bulunduğu konumu ilerletmektir.

index

04 - 19

0,6/1 kV Aluminum Cables

0,6/1 kV Alüminyum Kablolar

21 - 29

0,6/1 kV Copper Cables

0,6/1 kV Bakır Kablolar

31 - 34

0,3/0,6 kV Cables

0,3/0,6 kV Kablolar

36 - 70

Aluminum Conductors

Alüminyum İletkenler

0,6/1 kV Aluminum Cables

0,6/1 kV
Alüminyum Kablolar



0,6/1 kV AERIAL BUNDLED CONDUCTORS WITH PE - NEUTRAL NON-INSULATED

0,6/1 kV AER, Havai Alüminyum Örgülü İletken - PE kılıflı - Nötr çıplak

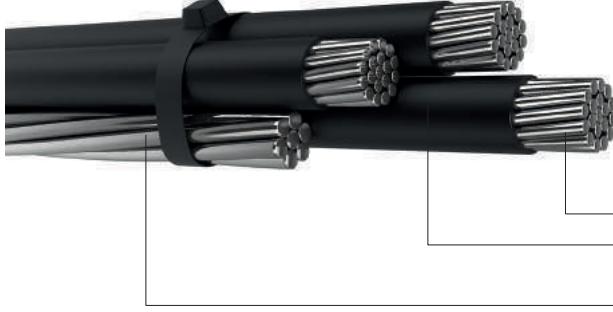

Çok Tellili Alüminyum İletken / Aluminum Conductor Compacted Class 2

Polietilen İzole / PE Insulation

Çıplak Askı Teli / Neutral Non-Insulated

APPLICATION:

Aerial outdoor installations, where there is no mechanical damage risk.

Maximum continuous normal operating temperature: 70 °C

Maximum short circuit temperature (Max. 5 minutes) : 135 °C

Standard: HD 626-S1 ,TSE 11654

Power cables with extruded insulation

Cables for rated voltages of 1 kV (Um = 1,2 kV)

KULLANIM ALANI:

Havai elektrik tesisatlarında, mekanik darbe riski olmayan uygulamalarda

En yüksek normal şartlarda sürekli çalışma sıcaklığı: 70 °C

En yüksek kısa devre akımında çalışma sıcaklığı: 135 °C

Standart: HD 626-S1

Kablolar - Beyan Gerilimi 1 kV (Um=1,2 kV) olan kablolar

No. X nominal area of the conductors / İletkenlerin sayısı ve anma kesit alanı	Covered Conductors / Yalıtılmış İletkenler					Neutral / Askı Teli			Complete Cable / İmalatı Tamamlanmış Kablo	
	No. X nominal area of the conductors / Sayı ve Kesit Alanı	Number of Wires Phase Conductor / Faz İletkenlerindeki tellerin sayısı	Diameter of Conductors (Approx.) / İletkenlerin Ortalama Çapı (Yaklaşık)	Max. Resistance at 20 °C / 20 °C'deki maksimum direnç	Min. Thickness of PE Cover / Min. Anma Yalıtım Kalınlığı	Nominal Diameter of Neutral (Approx.) / Askı Telinin Ortalama Çapı (Yaklaşık)	Min. Breaking Load / Min. Kopma Yüğü	Max. Resistance at 20 °C / 20 °C'deki maksimum direnç	Outer Diameter (Approx.) / Dış Çap (Yaklaşık)	Unit Weight (Approx.) / Birim Ağırlık (Yaklaşık)
mm ²	mm ²	Adet	mm	Ω/km	mm	mm	kN	Ω/km	mm	kg/km
1x16+25	1x16	7	4,4	1,910	1,4	5,9	7,4	1,38	13,0	140
1x25+35	1x25	7	5,9	1,200	1,4	6,9	10,3	0,986	15,5	190
1x35+50	1x35	7	6,9	0,868	1,6	8,1	14,2	0,72	17,8	260
1x50+70	1x50	7	8,1	0,641	1,6	9,7	20,6	0,493	21,0	360
1x70+95	1x70	7	9,7	0,443	1,8	11,4	27,9	0,363	24,5	505
3x16+25	3x16	7	4,4	1,910	1,4	5,9	7,4	1,38	13,1	270
3x25+35	3x25	7	5,9	1,200	1,4	6,9	10,3	0,986	20,0	390
3x35+50	3x35	7	6,9	0,868	1,6	8,1	14,2	0,72	23,0	530
3x50+70	3x50	7	8,1	0,641	1,6	9,7	20,6	0,493	26,0	700
3x70+95	3x70	7	9,7	0,443	1,8	11,4	27,9	0,363	31,0	990
3x95+95	3x95	19	11,4	0,320	1,8	11,4	27,9	0,363	34,0	1240
3x120+95	3x120	19	12,8	0,253	2,0	11,4	27,9	0,363	37,0	1510
3x150+95	3x150	19	14,1	0,206	2,0	11,4	27,9	0,363	39,5	1780
1x16+1x16+25	1x16	7	4,4	1,91	1,4	5,9	7,4	1,38	16,5	210
1x25+1x16+35	1x25	7	5,9	1,2	1,4	6,9	10,3	0,986	19,5	260
1x35+1x16+50	1x35	7	6,9	0,868	1,6	8,1	14,2	0,72	22,0	330
3x16+1x16+25	3x16	7	4,4	1,91	1,4	5,9	7,4	1,38	16,5	350
3x25+1x16+35	3x25	7	5,9	1,2	1,4	6,9	10,3	0,986	19,5	460
3x35+1x16+50	3x35	7	6,9	0,868	1,6	8,1	14,2	0,72	22,0	610
3x50+1x16+70	3x50	7	8,1	0,641	1,6	9,7	20,6	0,493	26,0	780
3x70+1x16+95	3x70	7	9,7	0,443	1,8	11,4	27,9	0,363	31,0	1080
3x95+1x16+95	3x95	19	11,4	0,320	1,8	11,4	27,9	0,363	34,0	1300
3x95+1x16+120	3x95	19	11,4	0,320	1,8	12,8	27,9	0,363	34,5	1380
3x120+1x16+95	3x120	19	12,8	0,253	2,0	11,4	27,9	0,363	37,0	1570
3x150+1x16+95	3x150	30	14,2	0,206	2,0	11,4	27,9	0,363	39,5	1850

*Aras Kablo has right to camend above values without declaring prior to change.

*Aras Kablo önceden haber vermeksizin yukarıdaki değerleri değiştirme hakkına sahiptir.

0,6/1 kV ABC - AERIAL BUNDLED CONDUCTORS WITH XLPE INSULATION

0,6/1 kV ABC - Alüminyum Örgülü İletken - XLPE kılıflı



Çok Telli Alüminyum İletken / Aluminum Conductor Compacted Class 2
XLPE İzole / XLPE Insulation

APPLICATION:

Aerial outdoor installations, where there is no mechanical damage risk.
Maximum continuous normal operating temperature: 90 °C
Maximum short circuit temperature: 250 °C
Standard: HD 626-S1
Power cables with extruded insulation
Cables for rated voltages of 1 kV ($U_m = 1,2$ kV)

KULLANIM ALANI:

Havai elektrik tesisatlarında, mekanik darbe riski olmayan uygulamalarda
En yüksek normal şartlarda sürekli çalışma sıcaklığı: 90 °C
En yüksek kısa devre akımında çalışma sıcaklığı: 250 °C
Standart: HD 626-S1
Kablolar - Beyan Gerilimi 1 kV ($U_m = 1,2$ kV) olan kablolar

No. X nominal area of the conductors / İletkenlerin sayısı ve anma kesit alanı	Min. no. of wires in phase conductor / Faz İletkeni için En Düşük Tel Sayısı	Nominal insulation thickness / Nominal İzole Kalınlığı			Overall diameter of Bundled (approx.) / Kablo Bükülü Dış Çapı (Yaklaşık)	Cable weight (approx.) / Kablo Birim Ağırlığı (Yaklaşık)	DC resistance (Max.) 20°C / En Yüksek DC Elektrik Direnci 20 °C'de			Current Carrying Capacity of Phase / Faz İletken Akım Taşıma Kapasitesi	Current Carrying Capacity of Street Lighting / Sokak Aydınlatma Akım Taşıma Kapasitesi
		Phase Conductor / Faz İletkeni	Neutral / Nötr Askı Teli	Street Lighting / Sokak Aydınlatma			Phase Conductor / Faz İletkeni	Neutral / Nötr Askı Teli	Street Lighting / Sokak Aydınlatma		
No.* sqmm		mm	mm	mm	mm	kg/km	Ω/km	Ω/km	Ω/km	A	A
2x16	6	1,20	-	-	15,0	136	1,910	-	-	83	-
4x16	6	1,20	-	-	18,0	272	1,910	-	-	83	-
2x25	6	1,40	-	-	18,0	200	1,200	-	-	112	-
4x25	6	1,40	-	-	22,0	400	1,200	-	-	112	-
5x25	6	1,40	-	-	24,0	500	1,200	-	-	112	-
6x25	6	1,40	-	-	26,0	600	1,200	-	-	112	-
3x25+25	6	1,40	1,40	-	22,0	400	1,200	1,380	-	112	-
3x25+54,6	6	1,40	1,60	-	30,0	515	1,200	0,630	-	112	-
3x35+54,6	6	1,60	1,60	-	33,0	630	0,868	0,630	-	-	-
3x35+54,6+2x25 (*)	6	1,60	1,60	1,40	33,5	835	0,868	0,630	1,200	-	112
3x50+54,6	6	1,60	1,60	-	34,0	750	0,641	0,630	-	168	-
3x50+54,6+2x25 (*)	6	1,60	1,60	1,40	35,0	955	0,641	0,630	1,200	168	112
4x50	6	1,60	1,60	-	34,0	720	0,641	-	-	168	-
4x50+2x25 (*)	6	1,60	-	1,40	35,5	920	0,641	-	1,200	168	112
3x70+54,6+2x25 (*)	12	1,80	1,60	1,40	38,0	1180	0,443	0,630	1,200	213	112
3x95+54,6	19	1,80	1,60	-	39,5	1210	0,320	0,630	-	258	-
3x95+54,6+2x25 (*)	19	1,80	1,60	1,40	40,0	1420	0,320	0,630	1,200	258	112
4x95	19	1,80	-	-	39,5	1340	0,320	-	-	258	-
4x95+2x25 (*)	19	1,80	-	1,40	40,5	1545	0,320	-	1,200	258	112
3x150+95+2x25 (*)	19	1,70	1,60	1,40	43,5	2050	0,206	0,343	1,200	344	112

*Aras Kablo has right to camend above values without declaring prior to change.

*Aras Kablo önceden haber vermeksizin yukarıdaki değerleri değiştirme hakkına sahiptir.

0,6/1 kV HDPE COVERED TWISTED ALUMINUM CONDUCTORS

0,6/1 kV Alüminyum Örgülü İletken - HDPE kılıflı



Çok Telli Alüminyum İletken / Aluminum Conductor Compacted Class 2
HDPE İzole / HDPE Insulation

APPLICATION:

Aerial outdoor installations, where there is no mechanical damage risk.
Maximum continuous normal operating temperature: 90 °C Maximum short circuit temperature: 200 °C
Standard: HD 626-S1
Power cables with extruded insulation
Cables for rated voltages of 1 kV ((Um = 1,2 kV)

KULLANIM ALANI:

Havai elektrik tesisatlarında, mekanik darbe riski olmayan uygulamalarda En yüksek normal şartlarda sürekli çalışma sıcaklığı: 90 °C En yüksek kısa devre akımında çalışma sıcaklığı: 200 °C
Standart: HD 626-S1
Kablolar - Beyan Gerilimi 1 kV (Um=1,2 kV) olan kablolar

Electrical and Mechanical Properties Aerial Bundled Conductors

No. X nominal area of the conductors / İletkenlerin sayısı ve anma kesit alanı	Min. no. of wires in phase conductor / Faz İletkeni için En Düşük Tel Sayısı	Nominal insulation thickness / Nominal İzole Kalınlığı			Overall diameter of Bundled (approx.) / Kablo Bükülü Dış Çapı (Yaklaşık)	Cable weight (approx.) / Kablo Birim Ağırlığı (Yaklaşık)	DC resistance (Max.) 20°C / En Yüksek DC Elektrik Direnci 20 °C'de			Current Carrying Capacity of Phase/ Faz İletken Akım Taşıma Kapasitesi	Current Carrying Capacity of Street Lighting / Sokak Aydınlatma Akım Taşıma Kapasitesi
		Phase Conductor / Faz İletkeni	Neutral / Nötr Askı Teli	Street Lighting / Sokak Aydınlatma			Phase Conductor / Faz İletkeni	Neutral / Nötr Askı Teli	Street Lighting / Sokak Aydınlatma		
No.* sqmm		mm	mm	mm	mm	kg/km	Ω/km	Ω/km	Ω/km	A	A
2x16	6	1,20	-	-	14,0	131	1,91	-	-	70	-
2x25	6	1,20	-	-	16,5	185	1,20	-	-	95	-
2x35	6	1,40	-	-	19,0	258	0,868	-	-	115	-
2x50	6	1,40	-	-	21,5	295	0,641	-	-	140	-
4x10	6	1,40	-	-	16,0	154	??	-	-	-	-
4x16	6	1,20	-	-	17,0	263	1,91	-	-	75	-
4x25	6	1,40	-	-	21,0	375	1,20	-	-	95	-
4x35	6	1,40	-	-	23,0	533	0,868	-	-	115	-
4x50	6	1,60	-	-	27,0	692	0,641	-	-	140	-
3x50+25+16	7	1,40	1,00	1,00	25,5	598	0,641	1,380	1,20	140	70
3x70+35+16	7	1,40	1,00	1,00	28,5	915	0,443	0,986	-	180	70
3x95+50+16	19	1,40	1,00	1,00	32,0	1150	0,320	0,720	1,20	-	70
3x120+70+16	19	1,60	1,00	1,00	35,5	1435	0,253	0,493	-	250	70
3x120+95+16	19	1,60	1,00	1,00	36,5	1536	0,253	0,363	1,20	250	70

*Aras Kablo has right to camend above values without declaring prior to change.
*Aras Kablo önceden haber vermeksizin yukarıdaki değerleri değiştirme hakkına sahiptir.

0,6/1 kV NAYY, SINGLE CORE POWER CABLE WITH ALUMINYUM CONDUCTOR, PVC INSULATION AND PVC JACKET

0,6/1 kV NAYY (YAVV), Tek Damarlı Enerji Kablosu, Alüminyum İletkenli,
PVC izoleli, PVC Kılıflı

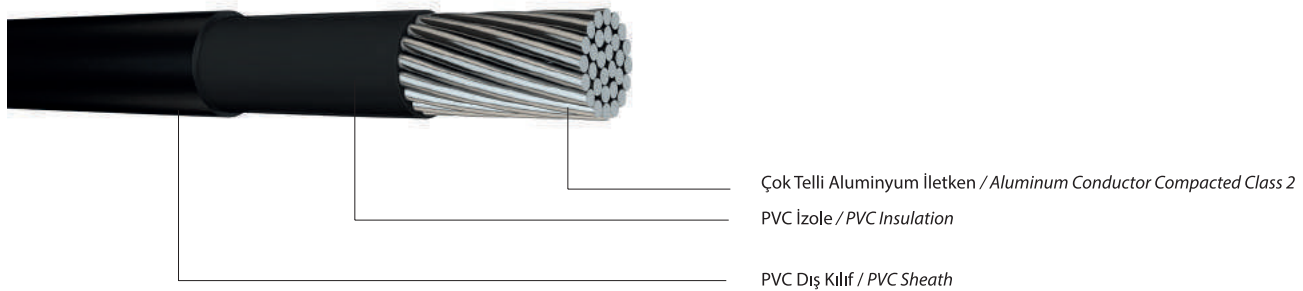

APPLICATION:

Indoor or outdoor installations, where there is no mechanical damage risk.
Maximum continuous normal operating temperature: 70 °C
Maximum short circuit temperature: 160 °C
Standard: IEC 60502-1
Power cables with extruded insulation
Cables for rated voltages of 1 kV (Um = 1,2 kV)

KULLANIM ALANI:

Bina içi ve dışı elektrik tesisatlarında, mekanik darbe riski olmayan uygulamalarda
En yüksek normal şartlarda sürekli çalışma sıcaklığı: 70 °C
En yüksek kısa devre akımında çalışma sıcaklığı: 160 °C
Standart: IEC 60502-1
Kablolar - Beyan Gerilimi 1 kV (Um=1,2 kV) olan kablolar

Electrical and Mechanical Properties – Round Conductors

(N)AYY-RM 1 (SINGLE) CORE

No. X nominal area of the conductors / İletkenlerin sayısı ve anma kesit alanı	Min. no. of wires in phase conductor / Faz İletkeni için En Düşük Tel Sayısı	Nominal insula- tion thickness / Nominal İzole Kalınlığı	Nominal outer sheath thickness / Nominal Dış Kılıf Kalınlığı	Overall diame- ter of Bundled (approx.) / Kablo Bükülü Dış Çapı (Yaklaşık)	Cable Unit We- ight (approx.) / Kablo Birim Ağırlığı (Yaklaşık)	DC resistance @ 20°C / DC Elektrik Direnç 20 °C'de	"Current Carrying Capacity / Akım Taşıma Kapasitesi"			
							In Air / Havada		"Under Ground / Yer Altında"	
							Flat / Düz	Trefoil / Üçgen	Flat / Düz	Trefoil / Üçgen
No.* sqmm		mm	mm	mm	mm	kg/km	Ω/km	Ω/km	Ω/km	Ω/km
1 conductor										
1x25	6	1,20	1,4	11,1	190	1,200	110	87	160	106
1x35	6	1,20	1,4	12,2	230	0,868	135	107	193	127
1x50	6	1,40	1,4	13,7	290	0,641	166	131	230	151
1x70	12	1,40	1,4	15,3	380	0,443	210	166	283	185
1x95	15	1,60	1,5	17,6	490	0,32	259	205	340	222
1x120	15	1,60	1,6	19,3	580	0,253	302	239	389	253
1x150	15	1,80	1,6	21,2	720	0,206	345	273	436	284
1x185	30	2,00	1,7	23,4	880	0,164	401	317	496	313
1x240	30	2,20	1,8	26,3	1100	0,125	479	378	578	375
1x300	30	2,40	1,9	28,9	1300	0,100	555	437	656	419
1x400	53	2,60	2,0	32,7	1700	0,0778	653	513	756	487
1x500	53	2,80	2,1	36,0	2250	0,0605	772	600	873	558

*Aras Kablo has right to amend above values without declaring prior to change.
*Aras Kablo önceden haber vermeksizin yukarıdaki değerleri değiştirme hakkına sahiptir.

0,6/1 kV NAYY MULTI CORE POWER CABLE WITH ALUMINYUM CONDUCTOR, PVC INSULATION AND PVC JACKET

0,6/1 kV NAYY (YAVV) Çok Damarlı Enerji Kablosu, Alüminyum İletkenli,
PVC izoleli, PVC Kılıflı

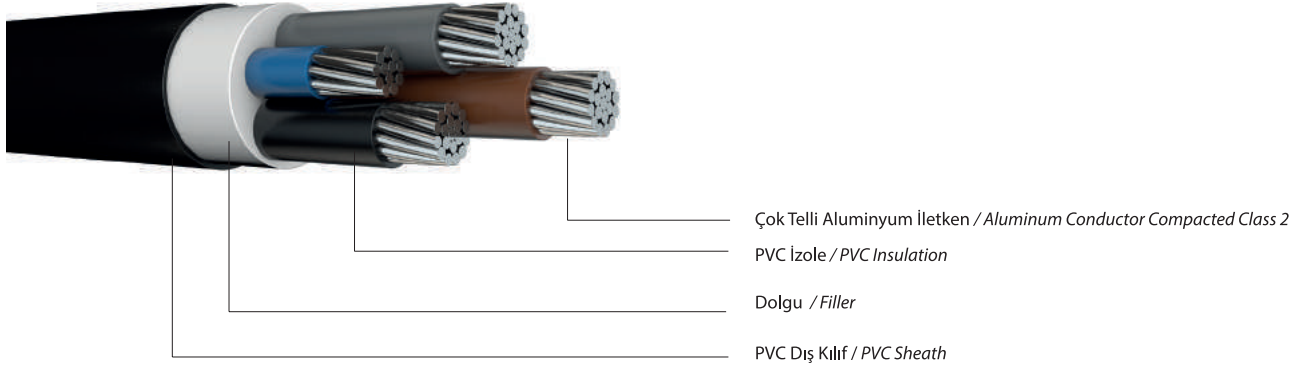

APPLICATION:

Indoor or outdoor installations, where there is no mechanical damage risk.
Maximum continuous normal operating temperature: 70 °C
Maximum short circuit temperature: 160 °C
Standard: IEC 60502-1
Power cables with extruded insulation
Cables for rated voltages of 1 kV (Um = 1,2 kV)

KULLANIM ALANI:

Bina içi ve dışı elektrik tesisatlarında, mekanik darbe riski olmayan uygulamalarda
En yüksek normal şartlarda sürekli çalışma sıcaklığı: 70 °C
En yüksek kısa devre akımında çalışma sıcaklığı: 160 °C
Standart: IEC 60502-1
Kablolar - Beyan Gerilimi 1 kV (Um=1,2 kV) olan kablolar

Electrical and Mechanical Properties – Round Conductors

(N)AYY-RM 3+1 CORE

No. X nominal area of the conductors / İletkenlerin sayısı ve anma kesit alanı	Min. no. of wires in phase conductor / Faz İletkeni için En Düşük Tel Sayısı	Nominal insulation thickness / Nominal İzole Kalınlığı	Nominal outer sheath thickness / Nominal Dış Kılıf Kalınlığı	Overall diameter of Bundled (approx.) / Kablo Bükülü Dış Çapı (Yaklaşık)	Cable Unit Weight (approx.) / Kablo Birim Ağırlığı (Yaklaşık)	DC resistance @ 20°C / DC Elektrik Direnci 20°C'de	"Current Carrying Capacity / Akım Taşıma Kapasitesi"	
							In Air / Havada	"Under Ground / Yer Altında"
No.* sqmm		mm	mm	mm	kg/km	Ω/km	A	A
3+1 conductors								
3x25+16	6	1,20	1,80	24	850	1,200	82	102
3x35+16	6	1,20	1,80	26	980	0,868	100	123
3x50+25	6	1,40	1,90	29	1330	0,641	119	144
3x70+35	12	1,40	2,00	33	1750	0,443	152	179
3x95+50	15	1,60	2,20	38	2300	0,320	186	215
3x120+70	15	1,60	2,30	42	2800	0,253	216	245
3x150+70	15	1,80	2,40	46	3300	0,206	246	275
3x185+95	30	2,00	2,60	52	4150	2,164	285	313
3x240+120	30	2,20	2,80	58	5150	0,125	338	364

*Aras Kablo has right to camend above values without declaring prior to change.

*Aras Kablo önceden haber vermeksizin yukarıdaki değerleri değiştirme hakkına sahiptir.

0,6/1 kV NAYY, MULTI CORE POWER CABLE WITH ALUMINYUM CONDUCTOR, PVC INSULATION AND PVC JACKET

0,6/1 kV NAYY (YAVV), Çok Damarlı Enerji Kablosu, Alüminyum İletkenli, PVC izoleli, PVC Kılıflı

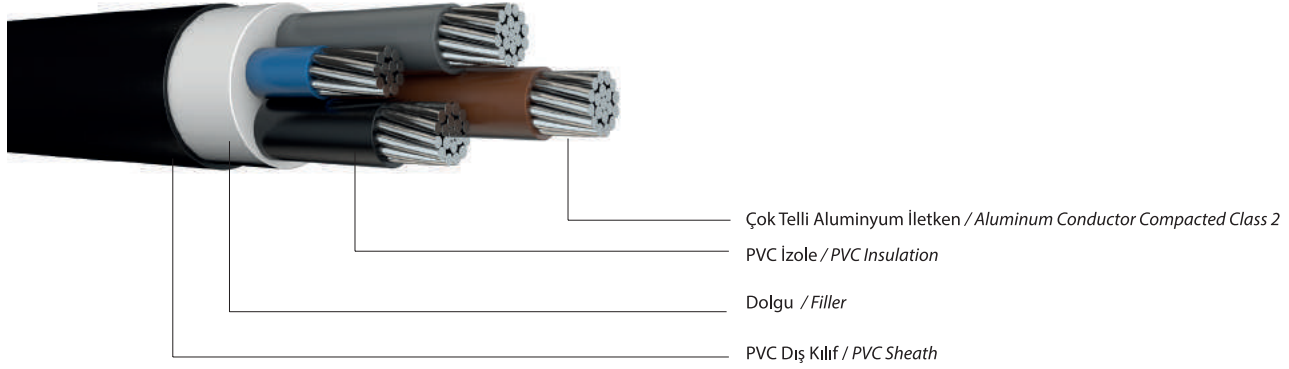

APPLICATION:

Indoor or outdoor installations, where there is no mechanical damage risk.
Maximum continuous normal operating temperature: 70 °C
Maximum short circuit temperature: 160 °C
Standard: IEC 60502-1
Power cables with extruded insulation
Cables for rated voltages of 1 kV (Um = 1,2 kV)

KULLANIM ALANI:

Bina içi ve dışı elektrik tesisatlarında, mekanik darbe riski olmayan uygulamalarda
En yüksek normal şartlarda sürekli çalışma sıcaklığı: 70 °C
En yüksek kısa devre akımında çalışma sıcaklığı: 160 °C
Standart: IEC 60502-1
Kablolar - Beyan Gerilimi 1 kV (Um=1,2 kV) olan kablolar

Electrical and Mechanical Properties – Round Conductors (N)AYY-RM 4 CORE

No. X nominal area of the conductors / İletkenlerin sayısı ve anma kesit alanı	Min. no. of wires in phase conductor / Faz İletkeni için En Düşük Tel Sayısı	Nominal insulation thickness / Nominal İzole Kalınlığı	Nominal outer sheath thickness / Nominal Dış Kılıf Kalınlığı	Overall diameter of Bundled (approx.) / Kablo Bükülü Dış Çapı (Yaklaşık)	Cable Unit Weight (approx.) / Kablo Birim Ağırlığı (Yaklaşık)	DC resistance @ 20°C / DC Elektrik Direnci 20°C'de	"Current Carrying Capacity / Akım Taşıma Kapasitesi"	
							In Air / Havada	"Under Ground / Yer Altında"
No.* sqmm		mm	mm	mm	kg/km	Ω/km	A	A
4 conductors								
4x16	6	1,00	1,80	1,8	640	1,910	-	-
4x25	6	1,20	1,80	1,8	920	1,200	82	102
4x35	6	1,20	1,80	1,8	1100	0,868	100	123
4x50	6	1,40	2,00	2,0	1480	0,641	119	144
4x70	12	1,40	2,10	2,1	1980	0,443	152	179
4x95	15	1,60	2,30	2,3	2600	0,320	186	215
4x120	15	1,60	2,40	2,4	3100	0,253	216	245
4x150	15	1,80	2,60	2,6	3800	0,206	246	275
4x185	30	2,00	2,70	2,7	4700	0,164	285	313
4x240	30	2,20	3,00	3,0	6900	0,125	338	364

* Aras Kablo has right to camend above values without declaring prior to change.

* Aras Kablo önceden haber vermeksizin yukarıdaki değerleri değiştirme hakkına sahiptir.

0,6/1 kV NAYY, MULTI CORE POWER CABLE WITH ALUMINYUM CONDUCTOR, PVC INSULATION AND PVC JACKET

0,6/1 kV NAYY (YAW), Çok Damarlı Enerji Kablosu, Alüminyum İletkenli, PVC izoleli, PVC Kılıflı

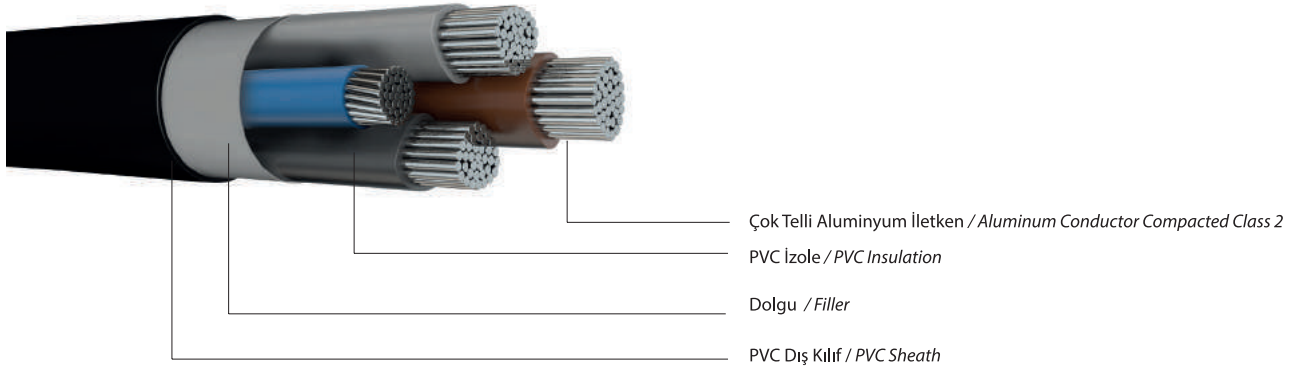

APPLICATION:

Indoor or outdoor installations, where there is no mechanical damage risk.
Maximum continuous normal operating temperature: 70 °C
Maximum short circuit temperature: 160 °C
Standard: IEC 60502-1
Power cables with extruded insulation
Cables for rated voltages of 1 kV (Um = 1,2 kV)

KULLANIM ALANI:

Bina içi ve dışı elektrik tesisatlarında, mekanik darbe riski olmayan uygulamalarda
En yüksek normal şartlarda sürekli çalışma sıcaklığı: 70 °C
En yüksek kısa devre akımında çalışma sıcaklığı: 160 °C
Standart: IEC 60502-1
Kablolar - Beyan Gerilimi 1 kV (Um=1,2 kV) olan kablolar

(N)AYY-SM 3+1 CORE

No. X nominal area of the conductors / İletkenlerin sayısı ve anma kesit alanı	Min. no. of wires in phase conductor / Faz İletkeni için En Düşük Tel Sayısı	Nominal insulation thickness / Nominal İzole Kalınlığı	Nominal outer sheath thickness / Nominal Dış Kılıf Kalınlığı	Overall diameter of Bundled (approx.) / Kablo Bükülü Dış Çapı (Yaklaşık)	Cable Unit Weight (approx.) / Kablo Birim Ağırlığı (Yaklaşık)	DC resistance @ 20°C / DC Elektrik Direnci 20 °C'de	"Current Carrying Capacity / Akım Taşıma Kapasitesi"	
							In Air / Havada	"Under Ground / Yer Altında"
No.* sqmm		mm	mm	mm	kg/km	Ω/km	A	A
3+1 conductors								
3x70+35	12	1,40	2,00	33,30	1350	0,443	152	179
3x95+50	15	1,60	2,20	37,70	1750	0,320	186	215
3x120+70	15	1,60	2,30	42,00	2250	0,253	216	245
3x150+70	15	1,80	2,40	45,00	2700	0,206	246	275
3x185+95	30	2,00	2,60	50,00	3200	2,164	285	313
3x240+120	30	2,20	2,80	57,00	4000	0,125	338	364

*Aras Kablo has right to camend above values without declaring prior to change.
*Aras Kablo önceden haber vermeksizin yukarıdaki değerleri değiştirme hakkına sahiptir.

0,6/1 kV NAYY, MULTI CORE POWER CABLE WITH ALUMINYUM CONDUCTOR, PVC INSULATION AND PVC JACKET

0,6/1 kV NAYY (YAVV), Çok Damarlı Enerji Kablosu, Alüminyum İletkenli, PVC izoleli, PVC Kılıflı

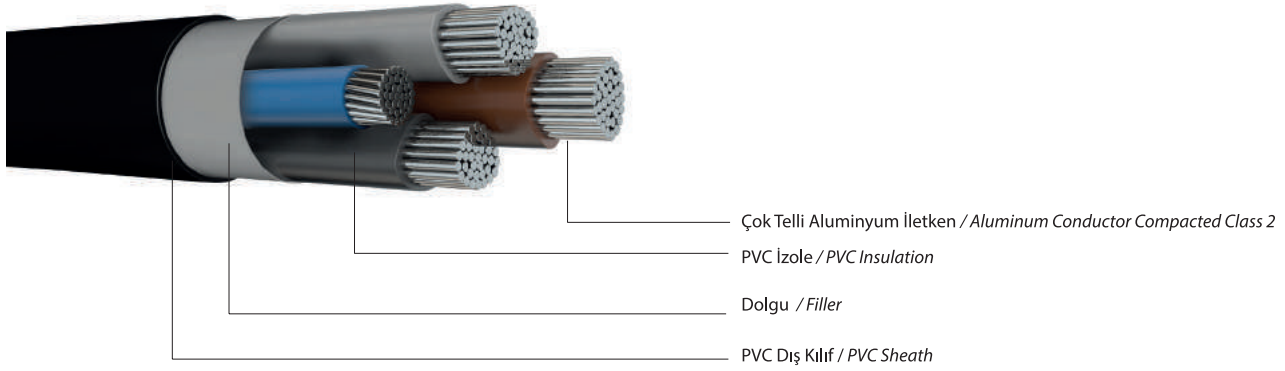

APPLICATION:

Indoor or outdoor installations, where there is no mechanical damage risk.
Maximum continuous normal operating temperature: 70 °C
Maximum short circuit temperature: 160 °C
Standard: IEC 60502-1
Power cables with extruded insulation
Cables for rated voltages of 1 kV (Um = 1,2 kV)

KULLANIM ALANI:

Bina içi ve dışı elektrik tesisatlarında, mekanik darbe riski olmayan uygulamalarda
En yüksek normal şartlarda sürekli çalışma sıcaklığı: 70 °C
En yüksek kısa devre akımında çalışma sıcaklığı: 160 °C
Standart: IEC 60502-1
Kablolar - Beyan Gerilimi 1 kV (Um=1,2 kV) olan kablolar

(N)AYY-SM 4 CORE

No. X nominal area of the conductors / İletkenlerin sayısı ve anma kesit alanı	Min. no. of wires in phase conductor / Faz İletkeni için En Düşük Tel Sayısı	Nominal insulation thickness / Nominal İzole Kalınlığı	Nominal outer sheath thickness / Nominal Dış Kılıf Kalınlığı	Overall diameter of Bundled (approx.) / Kablo Bükülü Dış Çapı (Yaklaşık)	Cable Unit Weight (approx.) / Kablo Birim Ağırlığı (Yaklaşık)	DC resistance @ 20°C / DC Elektrik Direnci 20 °C'de	"Current Carrying Capacity / Akım Taşıma Kapasitesi"	
							In Air / Havada	"Under Ground / Yer Altında"
No.* sqmm		mm	mm	mm	kg/km	Ω/km	A	A
4 conductors								
4x70	12	1,40	2,10	35,00	1500	0,443	152	179
4x95	15	1,60	2,30	40,00	1950	0,320	186	215
4x120	15	1,60	2,40	44,00	2350	0,253	216	245
4x150	15	1,80	2,50	48,00	2850	0,206	246	275
4x185	30	2,00	2,70	54,00	3600	0,164	285	313
4x240	30	2,20	2,90	60,00	4400	0,125	338	364

*Aras Kablo has right to camend above values without declaring prior to change.
*Aras Kablo önceden haber vermeksizin yukarıdaki değerleri değiştirme hakkına sahiptir.

0,6/1 kV NA2XY, SINGLE CORE POWER CABLE WITH ALUMINYUM CONDUCTOR, XLPE INSULATION AND PVC JACKET

0,6/1 kV NA2XY, Tek Damarlı Enerji Kablosu, Alüminyum İletkenli, XLPE İzoleli, PVC Kılıflı



Çok Tellî Alüminyum İletken / Aluminum Conductor Compacted Class 2
XLPE İzole / XLPE Insulation
PVC Dış Kılıf / PVC Sheath

APPLICATION:

Indoor or outdoor installations, where there is no mechanical damage risk.
Maximum continuous normal operating temperature: 90 °C
Maximum short circuit temperature: 250 °C
Standard: IEC 60502-1
Power cables with extruded insulation
Cables for rated voltages of 1 kV (Um = 1,2 kV)

KULLANIM ALANI:

Bina içi ve dışı elektrik tesisatlarında, mekanik darbe riski olmayan uygulamalarda
En yüksek normal şartlarda sürekli çalışma sıcaklığı: 90 °C
En yüksek kısa devre akımında çalışma sıcaklığı: 250 °C
Standart: IEC 60502-1
Kablolar - Beyan Gerilimi 1 kV (Um=1,2 kV) olan kablolar

Electrical and Mechanical Properties – Round Conductors

(N)A2XY-RM 1 (SINGLE) CORE

No. X nominal area of the conductors / İletkenlerin sayısı ve anma kesit alanı	Min. no. of wires in phase conductor / Faz İletkeni için En Düşük Tel Sayısı	Nominal insulation thickness / Nominal İzole Kalınlığı	Nominal outer sheath thickness / Nominal Dış Kılıf Kalınlığı	Overall diameter of Bundled (approx.) / Kablo Bükülü Dış Çapı (Yaklaşık)	Cable Unit Weight (approx.) / Kablo Birim Ağırlığı (Yaklaşık)	DC resistance @ 20°C / DC Elektrik Direnci 20 °C'de	"Current Carrying Capacity / Akım Taşıma Kapasitesi"			
							In Air / Havada		"Under Ground / Yer Altında"	
							Flat / Düz	Trefoil / Üçgen	Flat / Düz	Trefoil / Üçgen
No.* sqmm		mm	mm	mm	mm	Ω/km	A	A	A	A
1 conductor / 1 İletken										
1x25	6	0,90	1,4	10,3	165	1,200	136	106	177	114
1x35	6	0,90	1,4	11,3	200	0,868	166	130	212	136
1x50	6	1,00	1,4	12,7	245	0,641	205	161	252	162
1x70	12	1,10	1,4	14,8	330	0,443	260	204	310	199
1x95	15	1,10	1,5	16,5	420	0,32	321	252	372	238
1x120	15	1,20	1,5	18,0	510	0,253	376	295	425	272
1x150	15	1,40	1,6	20,2	630	0,206	431	339	476	305
1x185	30	1,60	1,6	22,5	780	0,164	501	395	541	347
1x240	30	1,70	1,7	25,1	975	0,125	600	472	631	404
1x300	30	1,80	1,8	27,6	1150	0,100	696	547	716	457
1x400	53	2,00	1,9	31,4	1545	0,0778	821	643	825	525
1x500	53	2,00	1,9	35,0	2100	0,0605	971	754	952	601
1x630	53	2,40	2,2	40,0	2550	0,0469	1151	882	1102	687

*Aras Kablo has right to camend above values without declaring prior to change.
*Aras Kablo önceden haber vermeksizin yukarıdaki değerleri değiştirme hakkına sahiptir.

0,6/1 kV NA2XY, MULTI CORE POWER CABLE WITH ALUMINYUM CONDUCTOR, XLPE INSULATION AND PVC JACKET

0,6/1 kV NA2XY, Çok Damarlı Enerji Kablosu, Alüminyum İletkenli, XLPE İzoleli, PVC Kılıflı

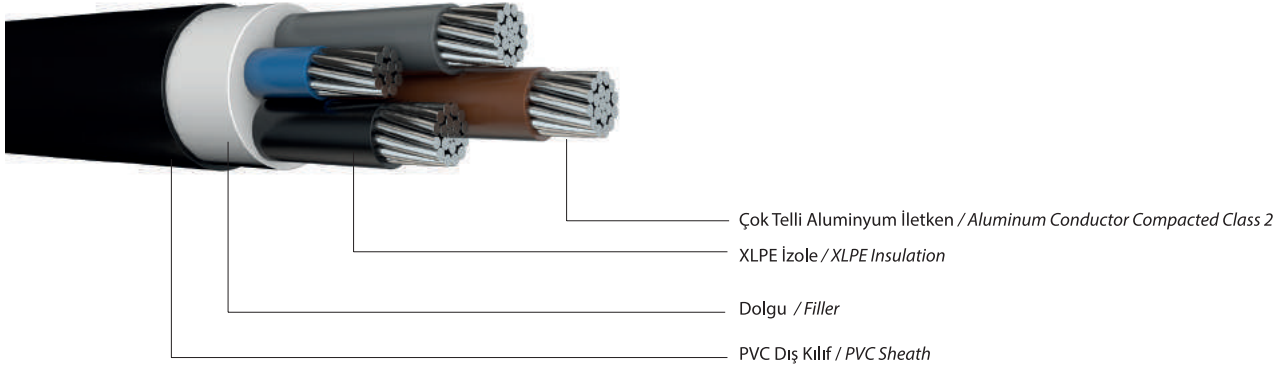

APPLICATION:

Indoor or outdoor installations, where there is no mechanical damage risk.
Maximum continuous normal operating temperature: 90 °C
Maximum short circuit temperature: 250 °C
Standard: IEC 60502-1
Power cables with extruded insulation
Cables for rated voltages of 1 kV (Um = 1,2 kV)

KULLANIM ALANI:

Bina içi ve dışı elektrik tesisatlarında, mekanik darbe riski olmayan uygulamalarda
En yüksek normal şartlarda sürekli çalışma sıcaklığı: 90 °C
En yüksek kısa devre akımında çalışma sıcaklığı: 250 °C
Standart: IEC 60502-1
Kablolar - Beyan Gerilimi 1 kV (Um=1,2 kV) olan kablolar

Electrical and Mechanical Properties – Round Conductors

(N)A2XY-RM 3+1 CORE

No. X nominal area of the conductors / İletkenlerin sayısı ve anma kesit alanı	Min. no. of wires in phase conductor / Faz İletkeni için En Düşük Tel Sayısı	Min. no. of wires in neutral conductor Phase/ Nötr İletkeni için En Düşük Tel Sayısı Nötr	Nominal insulation thickness Phase / Nominal İzolasyon Kalınlığı Faz	Nominal insulation thickness Neutral / Nominal İzolasyon Kalınlığı Nötr	Nominal outer sheath thickness / Nominal Dış Kılıf Kalınlığı	Overall diameter of Bundled (approx.) / Kablo Bükülü Dış Çapı (Yaklaşık)	Cable Unit Weight (approx.) / Kablo Birim Ağırlığı (Yaklaşık)	DC resistance @ 20°C / DC Elektrik Direnci 20 °C'de	"Current Carrying Capacity / Akım Taşıma Kapasitesi"	
									In Air / Havada	"Under Ground / Yer Altında"
No.* sqmm			mm	mm	mm	mm	kg/km	Ω/km	A	A
3+1 conductors / 3+1 İletken										
3x25+16	6	6	0,90	0,70	1,80	22,80	712	1,200	102	112
3x35+16	6	6	0,90	0,70	1,80	22,40	832	0,868	126	135
3x50+25	6	6	1,00	0,90	1,90	28,20	1115	0,641	149	158
3x70+35	12	6	1,10	0,90	2,00	32,70	1472	0,443	191	196
3x95+50	15	6	1,10	1,00	2,10	36,90	1930	0,320	234	234
3x120+70	15	12	1,20	1,10	2,30	41,50	2440	0,253	273	268
3x150+70	15	12	1,40	1,10	2,40	45,10	2900	0,206	311	300
3x185+95	30	15	1,60	1,10	2,60	50,20	3650	2,164	360	342
3x240+120	30	15	1,70	1,20	2,80	56,00	4550	0,125	427	398

*Aras Kablo has right to camend above values without declaring prior to change.

*Aras Kablo önceden haber vermeksizin yukarıdaki değerleri değiştirme hakkına sahiptir.

0,6/1 kV NA2XY, MULTI CORE POWER CABLE WITH ALUMINYUM CONDUCTOR, XLPE INSULATION AND PVC JACKET

0,6/1 kV NA2XY, Çok Damarlı Enerji Kablosu, Aluminyum İletkenli, XLPE izoleli, PVC Kılıflı

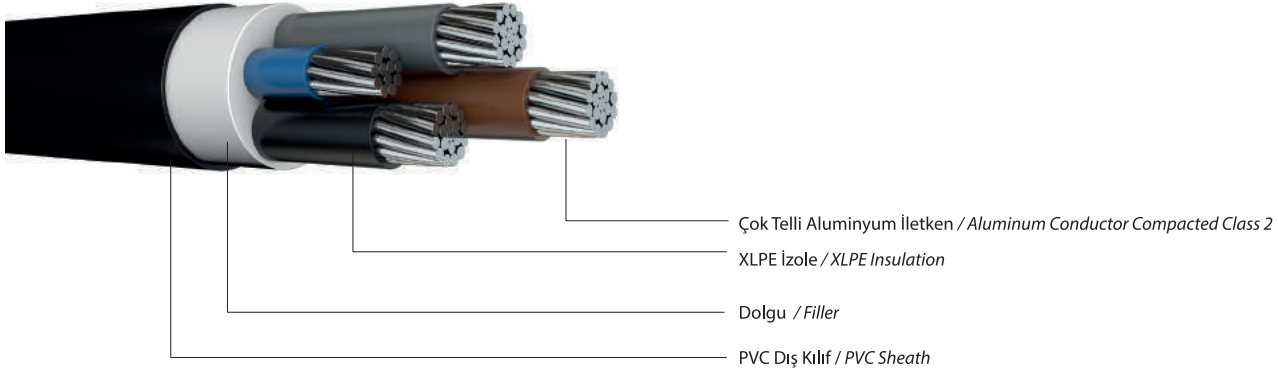

APPLICATION:

Indoor or outdoor installations, where there is no mechanical damage risk.
Maximum continuous normal operating temperature: 90 °C
Maximum short circuit temperature: 250 °C
Standard: IEC 60502-1
Power cables with extruded insulation
Cables for rated voltages of 1 kV ($U_m = 1,2$ kV)

KULLANIM ALANI:

Bina içi ve dışı elektrik tesisatlarında, mekanik darbe riski olmayan uygulamalarda
En yüksek normal şartlarda sürekli çalışma sıcaklığı: 90 °C
En yüksek kısa devre akımında çalışma sıcaklığı: 250 °C
Standart: IEC 60502-1
Kablolar - Beyan Gerilimi 1 kV ($U_m = 1,2$ kV) olan kablolar

Electrical and Mechanical Properties – Round Conductors (N)A2XY-RM 4 CORE

No. X nominal area of the conductors / İletkenlerin sayısı ve anma kesit alanı	Min. no. of wires in phase conductor / Faz İletkeni için En Düşük Tel Sayısı	Nominal insulation thickness / Nominal İzole Kalınlığı	Nominal outer sheath thickness / Nominal Dış Kılıf Kalınlığı	Overall diameter of Bundled (approx.) / Kablo Bükülü Dış Çapı (Yaklaşık)	Cable Unit Weight (approx.) / Kablo Birim Ağırlığı (Yaklaşık)	DC resistance @ 20°C / DC Elektrik Direnci 20 °C'de	"Current Carrying Capacity / Akım Taşıma Kapasitesi"	
							In Air / Havada	"Under Ground / Yer Altında"
4 conductors								
4x16	6	0,70	1,80	19,60	530	1,910	-	-
4x25	6	0,90	1,80	23,20	750	1,200	102	112
4x35	6	0,90	1,80	25,90	930	0,868	126	135
4x50	6	1,00	1,90	29,80	1240	0,641	149	158
4x70	12	1,10	2,00	34,40	1720	0,443	191	196
4x95	15	1,10	2,10	39,00	2170	0,320	234	234
4x120	15	1,20	2,30		2700	0,253	273	268
4x150	15	1,40	2,40	48,30	3350	0,206	311	300
4x185	30	1,60	2,60	54,00	4150	0,164	360	342
4x240	30	1,70	2,80	60,00	5200	0,125	427	398

*Aras Kablo has right to camend above values without declaring prior to change.

*Aras Kablo önceden haber vermeksizin yukarıdaki değerleri değiştirme hakkına sahiptir.

0,6/1 kV NA2XY, MULTI CORE POWER CABLE WITH ALUMINYUM CONDUCTOR, XLPE INSULATION AND PVC JACKET

0,6/1 kV NA2XY, Çok Damarlı Enerji Kablosu, Alüminyum İletkenli, XLPE İzoleli, PVC Kılıflı

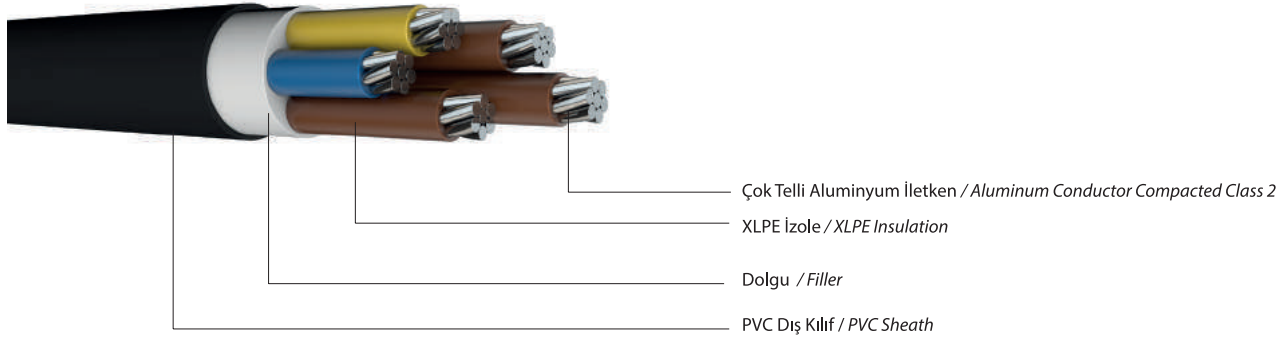

APPLICATION:

Indoor or outdoor installations, where there is no mechanical damage risk.
Maximum continuous normal operating temperature: 90 °C
Maximum short circuit temperature: 250 °C
Standard: IEC 60502-1
Power cables with extruded insulation
Cables for rated voltages of 1 kV ($U_m = 1,2$ kV)

KULLANIM ALANI:

Bina içi ve dışı elektrik tesisatlarında, mekanik darbe riski olmayan uygulamalarda
En yüksek normal şartlarda sürekli çalışma sıcaklığı: 90 °C
En yüksek kısa devre akımında çalışma sıcaklığı: 250 °C
Standart: IEC 60502-1
Kablolar - Beyan Gerilimi 1 kV ($U_m = 1,2$ kV) olan kablolar

Electrical and Mechanical Properties – Round Conductors (N)A2XY-RM 5 CORE

No. X nominal area of the conductors / İletkenlerin sayısı ve anma kesit alanı	Min. no. of wires in phase conductor / Faz İletkeni için En Düşük Tel Sayısı	Nominal insulation thickness / Nominal İzole Kalınlığı	Nominal outer sheath thickness / Nominal Dış Kılıf Kalınlığı	Overall diameter of Bundled (approx.) / Kablo Bükülü Dış Çapı (Yaklaşık)	Cable Unit Weight (approx.) / Kablo Birim Ağırlığı (Yaklaşık)	DC resistance @ 20°C / DC Elektrik Direnci 20°C'de	"Current Carrying Capacity / Akım Taşıma Kapasitesi"	
							In Air / Havada	"Under Ground / Yer Altında"
No.* sqmm		mm	mm	mm	kg/km	Ω/km	A	A
5 conductors								
5x16	6	0,70	1,80	21,30	650	1,910	-	-
5x25	6	0,90	1,80	26,00	950	1,200	102	112
5x35	6	0,90	1,80	28,00	1150	0,868	126	135
5x50	6	1,00	2,00	32,50	1550	0,641	149	158
5x70	12	1,10	2,10	38,50	2150	0,443	191	196
5x95	15	1,10	2,30	43,00	2800	0,320	234	234
5x120	15	1,20	2,40	47,00	3450	0,253	273	268
5x150	15	1,40	2,60	53,00	4300	0,206	311	300
5x185	30	1,60	2,80	59,00	5350	0,164	360	342
5x240	30	1,70	3,10	66,00	6700	0,125	427	398

*Aras Kablo has right to camend above values without declaring prior to change.

*Aras Kablo önceden haber vermeksizin yukarıdaki değerleri değiştirme hakkına sahiptir.

0,6/1 kV NA2XY, MULTI CORE POWER CABLE WITH ALUMINYUM CONDUCTOR, XLPE INSULATION AND PVC JACKET

0,6/1 kV NA2XY, Çok Damarlı Enerji Kablosu, Aluminyum İletkenli, XLPE izoleli, PVC Kılıflı

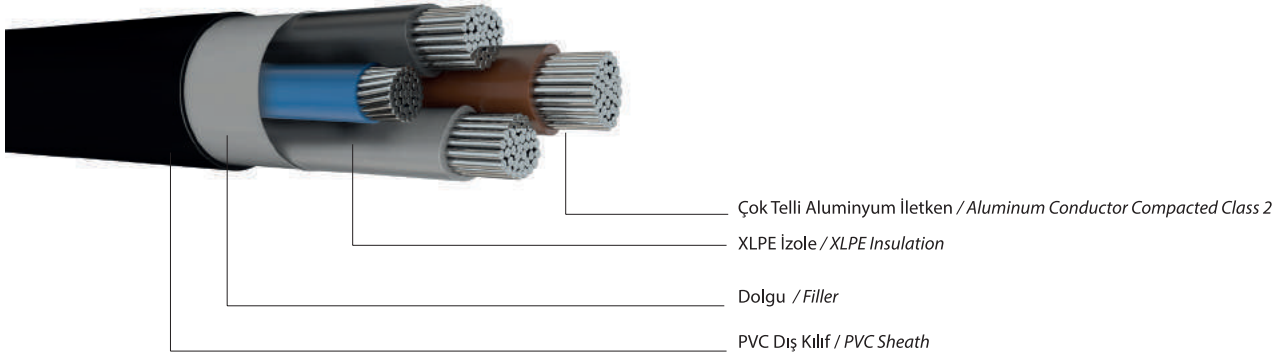

APPLICATION:

Indoor or outdoor installations, where there is no mechanical damage risk.
Maximum continuous normal operating temperature: 90 °C
Maximum short circuit temperature: 250 °C
Standard: IEC 60502-1
Power cables with extruded insulation
Cables for rated voltages of 1 kV (Um = 1,2 kV)

KULLANIM ALANI:

Bina içi ve dışı elektrik tesisatlarında, mekanik darbe riski olmayan uygulamalarda
En yüksek normal şartlarda sürekli çalışma sıcaklığı: 90 °C
En yüksek kısa devre akımında çalışma sıcaklığı: 250 °C
Standart: IEC 60502-1
Kablolar - Beyan Gerilimi 1 kV (Um=1,2 kV) olan kablolar

Electrical and Mechanical Properties – Round Conductors

(N)A2XY-SM 3+1 CORE

No. X nominal area of the conductors / İletkenlerin sayısı ve anma kesit alanı	Min. no. of wires in phase conductor / Faz İletkeni için En Düşük Tel Sayısı	Nominal insulation thickness / Nominal İzole Kalınlığı	Nominal outer sheath thickness / Nominal Dış Kılıf Kalınlığı	Overall diameter of Bundled (approx.) / Kablo Bükülü Dış Çapı (Yaklaşık)	Cable Unit Weight (approx.) / Kablo Birim Ağırlığı (Yaklaşık)	DC resistance @ 20°C / DC Elektrik Direnci 20 °C'de	"Current Carrying Capacity / Akım Taşıma Kapasitesi"	
							In Air / Havada	"Under Ground / Yer Altında"
No.* sqmm		mm	mm	mm	kg/km	Ω/km	A	A
3+1 conductors								
3x70+35	12	1,10	2,00	29,50	1130	0,443	191	196
3x95+50	15	1,10	2,10	32,60	1460	0,320	234	234
3x120+70	15	1,20	2,30	38,70	1820	0,253	273	268
3x150+70	15	1,40	2,40	41,70	2200	0,206	311	300
3x185+95	30	1,60	2,60	47,90	2700	0,164	360	342
3x240+120	30	1,70	2,80	54,00	3400	0,125	427	398

*Aras Kablo has right to camend above values without declaring prior to change.

*Aras Kablo önceden haber vermeksizin yukarıdaki değerleri değiştirme hakkına sahiptir.

0,6/1 kV NA2XY, MULTI CORE POWER CABLE WITH ALUMINYUM CONDUCTOR, XLPE INSULATION AND PVC JACKET

0,6/1 kV NA2XY, Çok Damarlı Enerji Kablosu, Alüminyum İletkenli, XLPE İzoleli, PVC Kılıflı

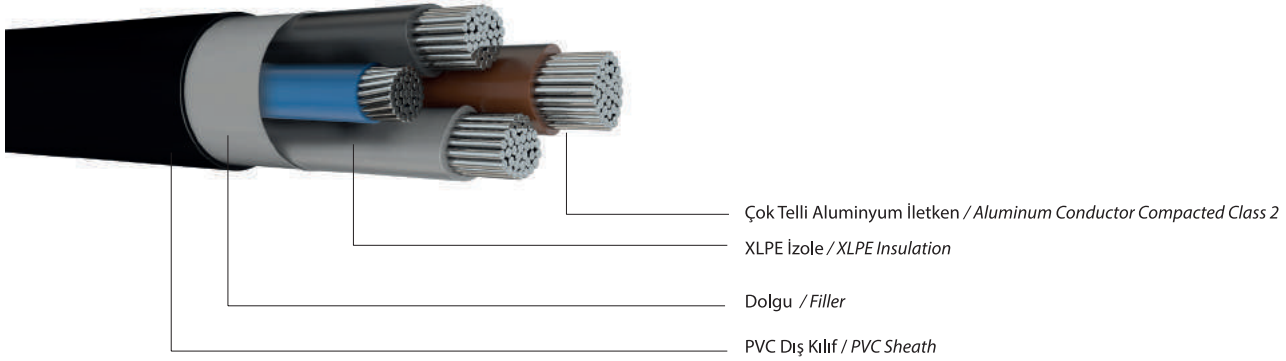

APPLICATION:

Indoor or outdoor installations, where there is no mechanical damage risk.
Maximum continuous normal operating temperature: 90 °C
Maximum short circuit temperature: 250 °C
Standard: IEC 60502-1
Power cables with extruded insulation
Cables for rated voltages of 1 kV (Um = 1,2 kV)

KULLANIM ALANI:

Bina içi ve dışı elektrik tesisatlarında, mekanik darbe riski olmayan uygulamalarda
En yüksek normal şartlarda sürekli çalışma sıcaklığı: 90 °C
En yüksek kısa devre akımında çalışma sıcaklığı: 250 °C
Standart: IEC 60502-1
Kablolar - Beyan Gerilimi 1 kV (Um=1,2 kV) olan kablolar

Electrical and Mechanical Properties – Round Conductors (N)A2XY-SM 4 CORE

No. X nominal area of the conductors / İletkenlerin sayısı ve anma kesit alanı	Min. no. of wires in phase conductor / Faz İletkeni için En Düşük Tel Sayısı	Nominal insulation thickness / Nominal İzole Kalınlığı	Nominal outer sheath thickness / Nominal Dış Kılıf Kalınlığı	Overall diameter of Bundled (approx.) / Kablo Bükülü Dış Çapı (Yaklaşık)	Cable Unit Weight (approx.) / Kablo Birim Ağırlığı (Yaklaşık)	DC resistance @ 20°C / DC Elektrik Direnci 20 °C'de	"Current Carrying Capacity / Akım Taşıma Kapasitesi"	
							In Air / Havada	"Under Ground / Yer Altında"
No.* sqmm		mm	mm	mm	kg/km	Ω/km	A	A
4 conductors								
4x70	12	1,10	2,00	31,20	1220	0,443	191	196
4x95	15	1,10	2,10	34,70	1630	0,320	234	234
4x120	15	1,20	2,30	40,70	2100	0,253	273	268
4x150	15	1,40	2,40	43,90	2550	0,206	311	300
4x185	30	1,60	2,60	50,20	3050	0,164	360	342
4x240	30	1,70	2,80	56,00	3950	0,125	427	398

*Aras Kablo has right to camend above values without declaring prior to change.

*Aras Kablo önceden haber vermeksizin yukarıdaki değerleri değiştirme hakkına sahiptir.

0,6/1 kV NAYFGbY, MULTI CORE POWER CABLE WITH ALUMINYUM CONDUCTOR, PVC INSULATION, STEEL WIRE AND TAPE ARMOUR PVC JACKET

0,6/1 kV NAYFGbY, Çok Damarlı Enerji Kablosu, Alüminyum İletkenli, PVC İzoleli, Çelik Tel ve Bant Zırlı, PVC Kılıflı

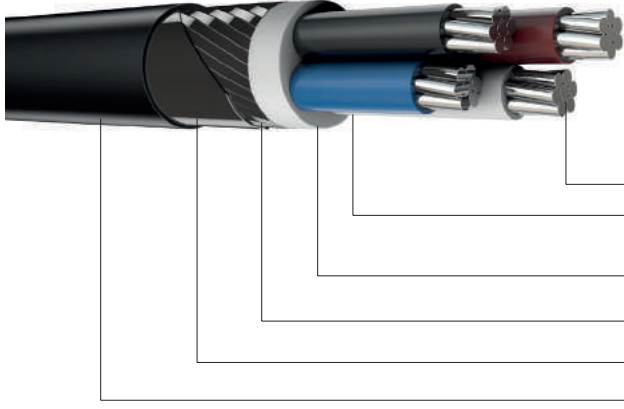

- Çok Telli Alüminyum İletken / Aluminum Conductor Compacted Class 2
- PVC İzole / PVC Insulation
- Dolgu / Filler
- Galvanizli Yassı Çelik Tel / Galvanized Flat Steel Wire
- Galvanizli Çelik Tel tutucu Band / Galvanized Steel Tape
- PVC Dış Kılıf / PVC Sheath

APPLICATION:

Indoor and outdoor installation direct burial preferably used where considerable mechanical damage risk
 Maximum continuous normal operating temperature: 70 °C
 Maximum short circuit temperature: 160 °C
 Standard: IEC 60502-1
 Power cables with extruded insulation
 Cables for rated voltages of 1 kV (Um = 1,2 kV)

KULLANIM ALANI:

Bina içi ve dışı elektrik tesisatlarında, tercihen kabul edilebilir mekanik risk olan bölgelerde.
 En yüksek normal şartlarda sürekli çalışma sıcaklığı: 70 °C
 En yüksek kısa devre akımında çalışma sıcaklığı: 160 °C
 Standart: IEC 60502-1
 Kablolar - Beyan Gerilimi 1 kV (Um=1,2 kV) olan kablolar

Electrical and Mechanical Properties – Round Conductors

(N)AYFGbY-RM 3+1 CORE

No. X nominal area of the conductors / İletkenlerin sayısı ve anma kesit alanı	Min. no. of wires in phase conductor / Faz İletkeni için En Düşük Tel Sayısı	Nominal insulation thickness / Nominal İzole Kalınlığı	Nominal outer sheath thickness / Nominal Dış Kılıf Kalınlığı	Overall diameter of Bundled (approx.) / Kablo Bükülü Dış Çapı (Yaklaşık)	Cable Unit Weight (approx.) / Kablo Birim Ağırlığı (Yaklaşık)	DC resistance @ 20°C / DC Elektrik Direnci 20 °C'de	"Current Carrying Capacity / Akım Taşıma Kapasitesi"	
							In Air / Havada	"Under Ground / Yer Altında"
No.* sqmm		mm	mm	mm	kg/km	Ω/km	A	A
3+1 conductors								
3x25+16	6	1,20	2,00	28,00	1400	1,200	82	102
3x35+16	6	1,20	2,10	29,00	1600	0,868	100	123
3x50+25	6	1,40	2,20	33,00	2050	0,641	119	144
3x70+35	12	1,40	2,30	38,00	2500	0,443	152	179
3x95+50	15	1,60	2,40	42,00	3300	0,320	186	215
3x120+70	15	1,60	2,60	46,00	3800	0,253	216	245
3x150+70	15	1,80	2,70	50,00	4400	0,206	246	275
3x185+95	30	2,00	2,90	55,00	5400	2,164	285	313
3x240+120	30	2,20	3,10	61,00	6500	0,125	338	364

*Aras Kablo has right to camend above values without declaring prior to change.

*Aras Kablo önceden haber vermeksizin yukarıdaki değerleri değiştirme hakkına sahiptir.

0,6/1 kV NAYFGbY, MULTI CORE POWER CABLE WITH ALUMINYUM CONDUCTOR, PVC INSULATION, STEEL WIRE AND TAPE ARMOUR PVC JACKET

0,6/1 kV NAYFGbY, Çok Damarlı Enerji Kablosu, Alüminyum İletkenli, PVC izoleli, Çelik Tel ve Bant Zırlı, PVC Kılıflı

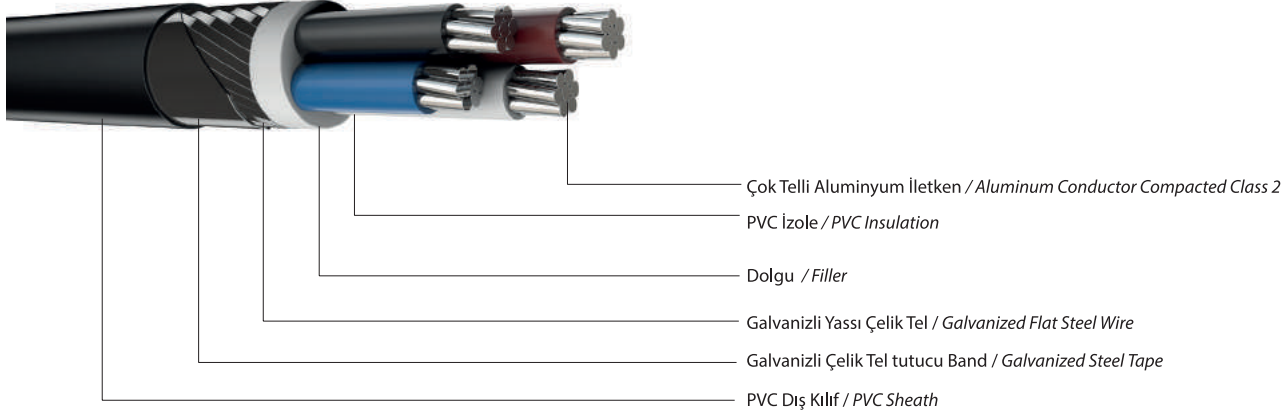

APPLICATION:

Indoor and outdoor installation direct burial preferably used where considerable mechanical damage risk
Maximum continuous normal operating temperature: 70 °C
Maximum short circuit temperature: 160 °C
Standard: IEC 60502-1
Power cables with extruded insulation
Cables for rated voltages of 1 kV (Um = 1,2 kV)

KULLANIM ALANI:

Bina içi ve dışı elektrik tesisatlarında, tercihen kabul edilebilir mekanik risk olan bölgelerde.
En yüksek normal şartlarda sürekli çalışma sıcaklığı: 70 °C
En yüksek kısa devre akımında çalışma sıcaklığı: 160 °C
Standart: IEC 60502-1
Kablolar - Beyan Gerilimi 1 kV (Um=1,2 kV) olan kablolar

Electrical and Mechanical Properties – Round Conductors

(N)AYFGbY-RM 4 CORE

No. X nominal area of the conductors / İletkenlerin sayısı ve anma kesit alanı	Min. no. of wires in phase conductor / Faz İletkeni için En Düşük Tel Sayısı	Nominal insulation thickness / Nominal İzole Kalınlığı	Nominal outer sheath thickness / Nominal Dış Kılıf Kalınlığı	Overall diameter of Bundled (approx.) / Kablo Bükülü Dış Çapı (Yaklaşık)	Cable Unit Weight (approx.) / Kablo Birim Ağırlığı (Yaklaşık)	DC resistance @ 20°C / DC Elektrik Direnci 20 °C'de	"Current Carrying Capacity / Akım Taşıma Kapasitesi"	
							In Air / Havada	"Under Ground / Yer Altında"
No.* sqmm		mm	mm	mm	kg/km	Ω/km	A	A
4 conductors								
4x16	6	1,00	2,00	25,00	1200	1,910		
4x25	6	1,20	2,00	29,00	1600	1,200	82	102
4x35	6	1,20	2,10	31,00	1850	0,868	100	123
4x50	6	1,40	2,20	35,00	2300	0,641	119	144
4x70	12	1,40	2,40	40,00	2850	0,443	152	179
4x95	15	1,60	2,50	44,00	3600	0,320	186	215
4x120	15	1,60	2,70	49,00	4250	0,253	216	245
4x150	15	1,80	2,80	53,00	5100	0,206	246	275
4x185	30	2,00	3,00	59,00	6200	2,164	285	313
4x240	30	2,20	3,20	65,00	7500	0,125	338	364

*Aras Kablo has right to camend above values without declaring prior to change.

*Aras Kablo önceden haber vermeksizin yukarıdaki değerleri değiştirme hakkına sahiptir.

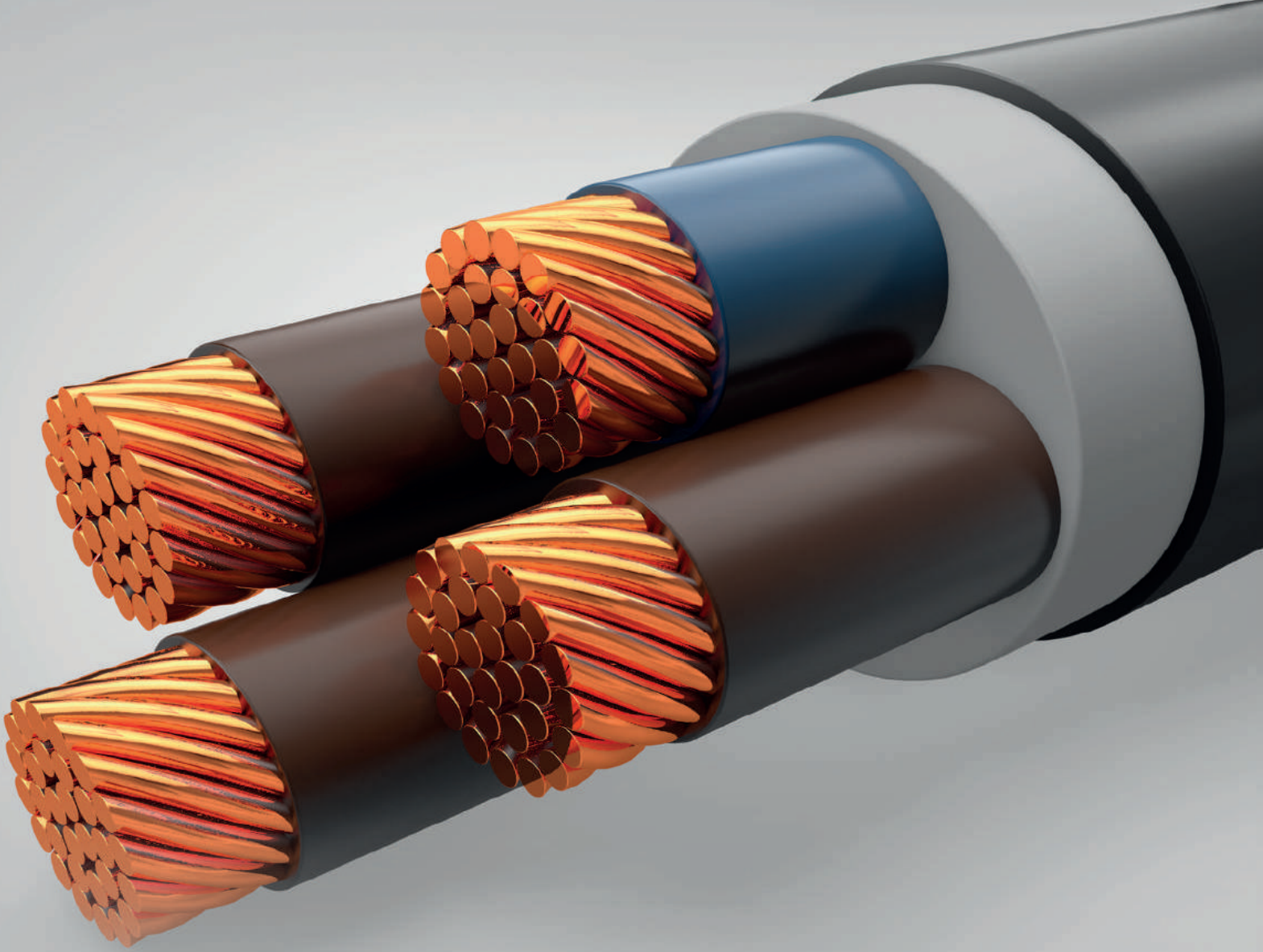

0,6/1 kV Copper Cables

0,6/1 kV
Bakır Kablolar

0,6/1 kV NYY, SINGLE CORE POWER CABLE WITH COPPER CONDUCTOR, PVC INSULATION AND PVC JACKET

0,6/1 kV NYY (YVV) Tek Damarlı Enerji Kablosu, Bakır İletkenli, PVC izoleli, PVC Kılıflı

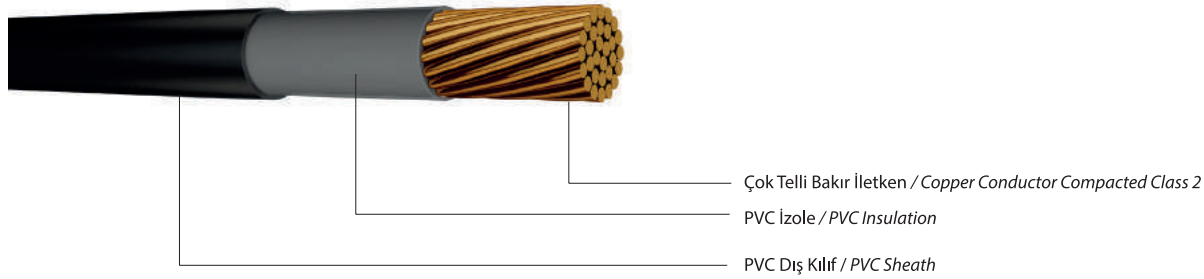

APPLICATION:

Indoor or outdoor installations, where there is no mechanical damage risk.
Maximum continuous normal operating temperature: 70 °C
Maximum short circuit temperature: 160 °C
Standard: IEC 60502-1
Power cables with extruded insulation
Cables for rated voltages of 1 kV (Um = 1,2 kV)

KULLANIM ALANI:

Bina içi ve dışı elektrik tesisatlarında, mekanik darbe riski olmayan uygulamalarda
En yüksek normal şartlarda sürekli çalışma sıcaklığı: 70 °C
En yüksek kısa devre akımında çalışma sıcaklığı: 160 °C
Standart: IEC 60502-1
Kablolar - Beyan Gerilimi 1 kV (Um=1,2 kV) olan kablolar

Electrical and Mechanical Properties – Round Conductors

(N)YY-RM 1 (SINGLE) CORE

No. X nominal area of the conductors / İletkenlerin sayısı ve anma kesit alanı	Min. no. of wires in phase conductor / Faz İletkeni için En Düşük Tel Sayısı	Nominal insulation thickness / Nominal İzole Kalınlığı	Nominal outer sheath thickness / Nominal Dış Kılıf Kalınlığı	Overall diameter of Bundled (approx.) / Kablo Bükülü Dış Çapı (Yaklaşık)	Cable Unit Weight (approx.) / Kablo Birim Ağırlığı (Yaklaşık)	DC resistance @ 20°C / DC Elektrik Direnci 20 °C'de	"Current Carrying Capacity / Akım Taşıma Kapasitesi"			
							In Air / Havada		"Under Ground / Yer Altında"	
							Flat / Düz	Trefoil / Üçgen	Flat / Düz	Trefoil / Üçgen
No.* sqmm		mm	mm	mm	kg/km	Ω/km	A	A	A	A
1 conductor										
1x16	6	1,00	1,4	9,8	240	1,150	107	84	160	107
1x25	6	1,20	1,4	11,4	340	0,727	144	114	208	138
1x35	6	1,20	1,4	12,4	440	0,524	176	139	250	164
1x50	6	1,40	1,4	13,8	600	0,387	214	169	296	195
1x70	12	1,40	1,4	15,6	800	0,268	270	213	365	238
1x95	15	1,60	1,5	17,7	1070	0,193	334	264	438	286
1x120	18	1,60	1,5	19,0	1310	0,153	389	307	501	325
1x150	18	1,80	1,7	21,3	1630	0,124	446	352	563	365
1x185	30	2,00	1,8	23,6	2000	0,0991	516	406	639	413
1x240	34	2,20	1,8	26,2	2560	0,0754	618	483	746	479
1x300	34	2,40	1,9	28,8	3170	0,0601	717	557	848	541
1x400	53	2,60	2,0	32,9	4170	0,0470	843	646	975	614

*Aras Kablo has right to amend above values without declaring prior to change.

*Aras Kablo önceden haber vermeksizin yukarıdaki değerleri değiştirme hakkına sahiptir.

0,6/1 kV NYY, MULTI CORE POWER CABLE WITH COPPER CONDUCTOR, PVC INSULATION AND PVC JACKET

0,6/1 kV NYY (YVV), Çok Damarlı Enerji Kablosu, Bakır İletkenli, PVC izoleli, PVC Kılıflı

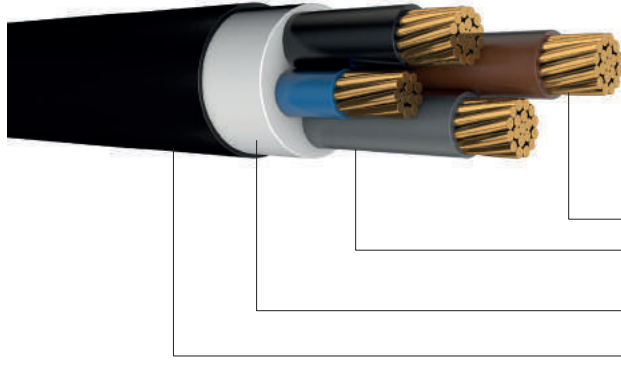

- Çok Telli Bakır İletken / *Copper Conductor Compacted Class 2*
- PVC İzole / *PVC Insulation*
- Dolgu / *Filler*
- PVC Dış Kılıf / *PVC Sheath*

APPLICATION:

Indoor or outdoor installations, where there is no mechanical damage risk.
Maximum continuous normal operating temperature: 70 °C
Maximum short circuit temperature: 160 °C
Standard: IEC 60502-1
Power cables with extruded insulation
Cables for rated voltages of 1 kV ($U_m = 1,2$ kV)

KULLANIM ALANI:

Bina içi ve dışı elektrik tesisatlarında, mekanik darbe riski olmayan uygulamalarda
En yüksek normal şartlarda sürekli çalışma sıcaklığı: 70 °C
En yüksek kısa devre akımında çalışma sıcaklığı: 160 °C
Standart: IEC 60502-1
Kablolar - Beyan Gerilimi 1 kV ($U_m = 1,2$ kV) olan kablolar

Electrical and Mechanical Properties – Round Conductors (N)YY-RM 3+1 CORE

No. X nominal area of the conductors / İletkenlerin sayısı ve anma kesit alanı	Min. no. of wires in phase conductor / Faz İletkeni için En Düşük Tel Sayısı	Nominal insulation thickness / Nominal İzole Kalınlığı	Nominal outer sheath thickness / Nominal Dış Kılıf Kalınlığı	Overall diameter of Bundled (approx.) / Kablo Bükülü Dış Çapı (Yaklaşık)	Cable Unit Weight (approx.) / Kablo Birim Ağırlığı (Yaklaşık)	DC resistance @ 20°C / DC Elektrik Direnci 20 °C'de	"Current Carrying Capacity / Akım Taşıma Kapasitesi"	
							In Air / Havada	"Under Ground / Yer Altında"
No.* sqmm		mm	mm	mm	kg/km	Ω/km	A	A
3+1 conductors								
3x16+10	6	1,00	1,80	21,20	980	1,150	79	102
3x25+16	6	1,20	1,80	24,50	1400	0,727	106	133
3x35+16	6	1,20	1,80	26,50	1740	0,524	129	159
3x50+25	6	1,40	1,90	30,40	2400	0,387	157	188
3x70+35	12	1,40	2,00	34,80	3260	0,268	199	232
3x95+50	15	1,60	2,20	39,40	4340	0,193	246	280
3x120+70	15	1,60	2,30	43,80	5450	0,153	285	318
3x150+70	15	1,80	2,40	47,40	6500	0,124	326	359
3x185+95	30	2,00	2,60	52,70	8080	0,0991	374	406
3x240+120	30	2,20	2,80	58,80	10260	0,0754	445	473

*Aras Kablo has right to camend above values without declaring prior to change.
*Aras Kablo önceden haber vermeksizin yukarıdaki değerleri değiştirme hakkına sahiptir.

0,6/1 kV NYY, MULTI CORE POWER CABLE WITH COPPER CONDUCTOR, PVC INSULATION AND PVC JACKET

0,6/1 kV NYY (YVV), Çok Damarlı Enerji Kablosu, Bakır İletkenli, PVC izoleli, PVC Kılıflı

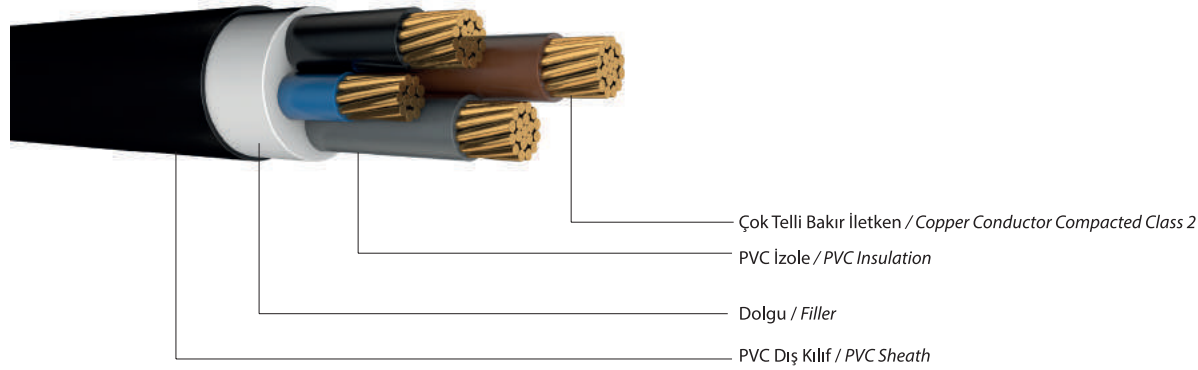

APPLICATION:

Indoor or outdoor installations, where there is no mechanical damage risk.
Maximum continuous normal operating temperature: 70 °C
Maximum short circuit temperature: 160 °C
Standard: IEC 60502-1
Power cables with extruded insulation
Cables for rated voltages of 1 kV (Um = 1,2 kV)

KULLANIM ALANI:

Bina içi ve dışı elektrik tesisatlarında, mekanik darbe riski olmayan uygulamalarda
En yüksek normal şartlarda sürekli çalışma sıcaklığı: 70 °C
En yüksek kısa devre akımında çalışma sıcaklığı: 160 °C
Standart: IEC 60502-1
Kablolar - Beyan Gerilimi 1 kV (Um=1,2 kV) olan kablolar

Electrical and Mechanical Properties – Round Conductors (N)YY-RM 4 CORE

No. X nominal area of the conductors / İletkenlerin sayısı ve anma kesit alanı	Min. no. of wires in phase conductor / Faz İletkeni için En Düşük Tel Sayısı	Nominal insulation thickness / Nominal İzole Kalınlığı	Nominal outer sheath thickness / Nominal Dış Kılıf Kalınlığı	Overall diameter of Bundled (approx.) / Kablo Bükülü Dış Çapı (Yaklaşık)	Cable Unit Weight (approx.) / Kablo Birim Ağırlığı (Yaklaşık)	DC resistance @ 20°C / DC Elektrik Direnci 20 °C'de	"Current Carrying Capacity / Akım Taşıma Kapasitesi"	
							In Air / Havada	"Under Ground / Yer Altında"
No.* sqmm		mm	mm	mm	kg/km	Ω/km	A	A
4 conductors								
4x16	6	1,00	1,80	21,80	1050	1,150	79	102
4x25	6	1,20	1,80	25,40	1530	0,727	106	133
4x35	6	1,20	1,80	28,00	1980	0,524	129	159
4x50	6	1,40	1,90	31,80	2740	0,387	157	188
4x70	12	1,40	2,10	37,00	3700	0,268	199	232
4x95	15	1,60	2,30	41,90	4900	0,193	246	280
4x120	15	1,60	2,40	46,00	6050	0,153	285	318
4x150	15	1,80	2,50	50,80	7500	0,124	326	359
4x185	30	2,00	2,70	56,30	9200	0,0991	374	406
4x240	30	2,20	2,90	63,00	11750	0,0754	445	473

*Aras Kablo has right to camend above values without declaring prior to change.

*Aras Kablo önceden haber vermeksizin yukarıdaki değerleri değiştirme hakkına sahiptir.

0,6/1 kV NYY-F, SINGLE CORE POWER CABLE WITH COPPER CONDUCTOR, PVC INSULATION AND PVC JACKET

0,6/1 kV NYY-F, Tek Damarlı En Yık Kılıf, Bakır İletkenli, PVC İzoleli,

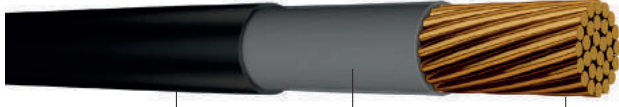

Çok Telli Bakır İletken / Copper Conductor Compacted Class 2

PVC İzole / PVC Insulation

PVC Dış Kılıf / PVC Sheath

APPLICATION:

Indoor or outdoor installations, where there is no mechanical damage risk.
Maximum continuous normal operating temperature: 70 °C
Maximum short circuit temperature: 160 °C
Standard: IEC 60502-1
Power cables with extruded insulation
Cables for rated voltages of 1 kV (Um = 1,2 kV)

KULLANIM ALANI:

Bina içi ve dışı elektrik tesisatlarında, mekanik darbe riski olmayan uygulamalarda
En yüksek normal şartlarda sürekli çalışma sıcaklığı: 70 °C
En yüksek kısa devre akımında çalışma sıcaklığı: 160 °C
Standart: IEC 60502-1
Kablolar - Beyan Gerilimi 1 kV (Um=1,2 kV) olan kablolar

Electrical and Mechanical Properties – Round Conductors

No. X nominal area of the conductors / İletkenlerin sayısı ve anma kesit alanı	Overall diameter of Bundled (approx.) / Kablo Bükülü Dış Çapı (Yaklaşık)	Cable Unit Weight (approx.) / Kablo Birim Ağırlığı (Yaklaşık)	DC resistance @ 20°C / DC Elektrik Direnç 20 °C'de	"Current Carrying Capacity / Akım Taşıma Kapasitesi"	
				In Air / Havada	"Under Ground / Yer Altında"
No.* sqmm	mm	kg/km	Ω/km	A	A
1 conductors					
1x0,5	2,10	11			
1x0,75	2,40	13			
1x1,0	2,70	15	19,50	12	18
1x1,5	2,90	19	13,30	18	22
1x2,5	3,60	30	7,98	23	30
1x4	4,50	44	4,95	27	38
1x6	5,00	65	3,30	31	51
1x10	6,50	115	1,91	42	75
1x16	8,20	173	1,21	60	92
1x25	9,60	275	0,78	82	125
1x35	11,30	370	0,554	105	153
1x50	13,50	508	0,386	130	190
1x70	15,10	709	0,272	162	247
1x95	17,50	952	0,206	195	289
1x120	19,50	1181	0,161	230	341
1x150	21,20	1482	0,129		390
1x185	25,30	1843	0,106		446
1x240	29,70	2463	0,0801		525
1x300	32,00	2960	0,0623		

*Aras Kablo has right to camend above values without declaring prior to change.

*Aras Kablo önceden haber vermeksizin yukarıdaki değerleri değiştirme hakkına sahiptir.

0,6/1 kV N2XY, SINGLE CORE POWER CABLE WITH COPPER CONDUCTOR, XLPE INSULATION AND PVC JACKET

0,6/1 kV N2XY, Tek Damarlı Enerji Kablosu, Bakır İletkenli, XLPE izoleli, PVC Kılıflı

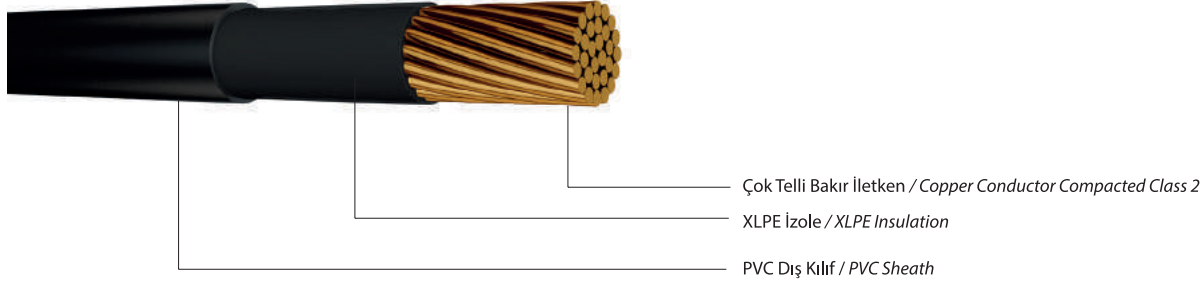

APPLICATION:

Indoor or outdoor installations, where there is no mechanical damage risk.
Maximum continuous normal operating temperature: 90 °C
Maximum short circuit temperature: 250 °C
Standard: IEC 60502-1
Power cables with extruded insulation
Cables for rated voltages of 1 kV ((Um = 1,2 kV)

KULLANIM ALANI:

Bina içi ve dışı elektrik tesisatlarında, mekanik darbe riski olmayan uygulamalarda
En yüksek normal şartlarda sürekli çalışma sıcaklığı: 90 °C
En yüksek kısa devre akımında çalışma sıcaklığı: 250 °C
Standart: IEC 60502-1
Kablolar - Beyan Gerilimi 1 kV (Um=1,2 kV) olan kablolar

Electrical and Mechanical Properties – Round Conductors

(N)2XY-RM 1 (SINGLE) CORE

No. X nominal area of the conductors / İletkenlerin sayısı ve anma kesit alanı	Min. no. of wires in phase conductor / Faz İletkeni için En Düşük Tel Sayısı	Nominal insulation thickness / Nominal İzole Kalınlığı	Nominal outer sheath thickness / Nominal Dış Kılıf Kalınlığı	Overall diameter of Bundled (approx.) / Kablo Bükülü Dış Çapı (Yaklaşık)	Cable Unit Weight (approx.) / Kablo Birim Ağırlığı (Yaklaşık)	DC resistance @ 20°C / DC Elektrik Direnci 20 °C'de	"Current Carrying Capacity / Akım Taşıma Kapasitesi"			
							In Air / Havada		"Under Ground / Yer Altında"	
							Flat / Düz	Trefoil / Üçgen	Flat / Düz	Trefoil / Üçgen
No.* sqmm		mm	mm	mm	kg/km	Ω/km	A	A	A	A
1 conductor										
1x16	6	0,70	1,3	9,0	210	1,150	131	102	176	115
1x25	6	0,90	1,3	10,7	310	0,727	177	138	229	148
1x35	6	0,90	1,3	11,8	410	0,524	217	170	275	177
1x50	6	1,00	1,4	12,9	550	0,387	265	207	326	209
1x70	12	1,10	1,4	15,0	750	0,268	336	263	400	256
1x95	15	1,10	1,4	16,4	990	0,193	415	325	480	307
1x120	18	1,20	1,5	18,4	1240	0,153	485	380	548	349
1x150	18	1,40	1,6	20,0	1540	0,124	557	437	616	393
1x185	30	1,60	1,7	22,5	1890	0,0991	646	507	698	445
1x240	34	1,70	1,8	25,1	2420	0,0754	774	604	815	517
1x300	34	1,80	1,8	27,7	2990	0,0601	901	697	927	583
1x400	53	2,00	2,0	31,5	3950	0,0470	1060	811	1064	663

*Aras Kablo has right to amend above values without declaring prior to change.

*Aras Kablo önceden haber vermeksizin yukarıdaki değerleri değiştirme hakkına sahiptir.

0,6/1 kV N2XY, MULTI CORE POWER CABLE WITH COPPER CONDUCTOR, XLPE INSULATION AND PVC JACKET

0,6/1 kV N2XY, Çok Damarlı Enerji Kablosu, Bakır İletkenli, XLPE İzoleli, PVC Kılıflı

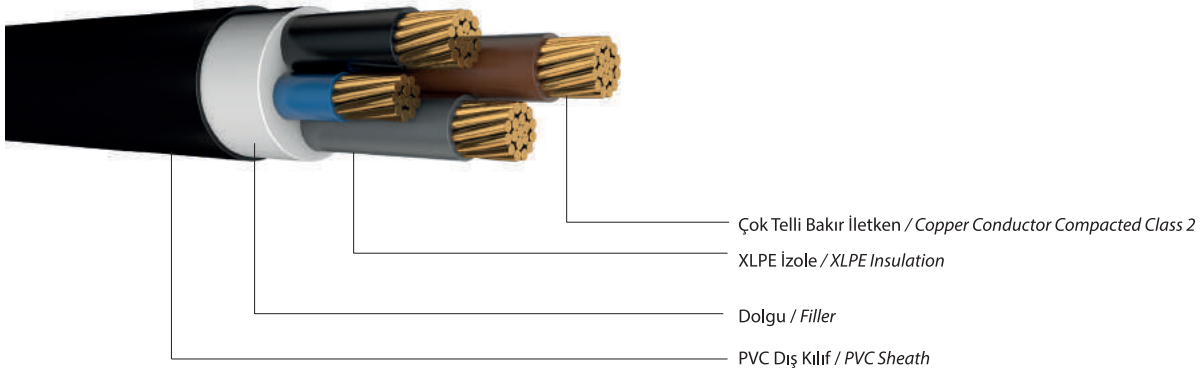

APPLICATION:

Indoor or outdoor installations, where there is no mechanical damage risk.
Maximum continuous normal operating temperature: 90 °C
Maximum short circuit temperature: 250 °C
Standard: IEC 60502-1
Power cables with extruded insulation
Cables for rated voltages of 1 kV (Um = 1,2 kV)

KULLANIM ALANI:

Bina içi ve dışı elektrik tesisatlarında, mekanik darbe riski olmayan uygulamalarda
En yüksek normal şartlarda sürekli çalışma sıcaklığı: 90 °C
En yüksek kısa devre akımında çalışma sıcaklığı: 250 °C
Standart: IEC 60502-1
Kablolar - Beyan Gerilimi 1 kV (Um=1,2 kV) olan kablolar

Electrical and Mechanical Properties – Round Conductors (N)2XY-RM 3+1 CORE

No. X nominal area of the conductors / İletkenlerin sayısı ve anma kesit alanı	Min. no. of wires in phase conductor / Faz İletkeni için En Düşük Tel Sayısı	Nominal insulation thickness / Nominal İzole Kalınlığı	Nominal outer sheath thickness / Nominal. Dış Kılıf Kalınlığı	Overall diameter of Bundled (approx.) / Kablo Bükülü Dış Çapı (Yaklaşık)	Cable Unit Weight (approx.) / Kablo Birim Ağırlığı (Yaklaşık)	DC resistance @ 20°C / DC Elektrik Direnci 20°C'de	"Current Carrying Capacity / Akım Taşıma Kapasitesi"	
							In Air / Havada	"Under Ground / Yer Altında"
No.* sqmm		mm	mm	mm	kg/km	Ω/km	A	A
3+1 conductors								
3x16+10	6	0,70	1,80	19,70	860	1,150	98	112
3x25+16	6	0,90	1,80	23,00	1260	0,727	133	145
3x35+16	6	0,90	1,80	25,00	1580	0,524	162	174
3x50+25	6	1,00	1,90	28,00	2200	0,387	197	206
3x70+35	12	1,10	2,00	33,40	3030	0,268	250	254
3x95+50	15	1,10	2,20	36,70	3980	0,193	308	305
3x120+70	18	1,20	2,30	41,90	5100	0,153	359	348
3x150+70	18	1,40	2,40	45,60	6100	0,124	412	392
3x185+95	30	1,60	2,60	50,40	7580	0,0991	475	444
3x240+120	34	1,70	2,80	56,20	9600	0,0754	564	517

*Aras Kablo has right to camend above values without declaring prior to change.
*Aras Kablo önceden haber vermeksizin yukarıdaki değerleri değiştirme hakkına sahiptir.

0,6/1 kV N2XY, MULTI CORE POWER CABLE WITH COPPER CONDUCTOR, XLPE INSULATION AND PVC JACKET

0,6/1 kV N2XY, Çok Damarlı Enerji Kablosu, Bakır İletkenli, XLPE izoleli, PVC Kılıflı

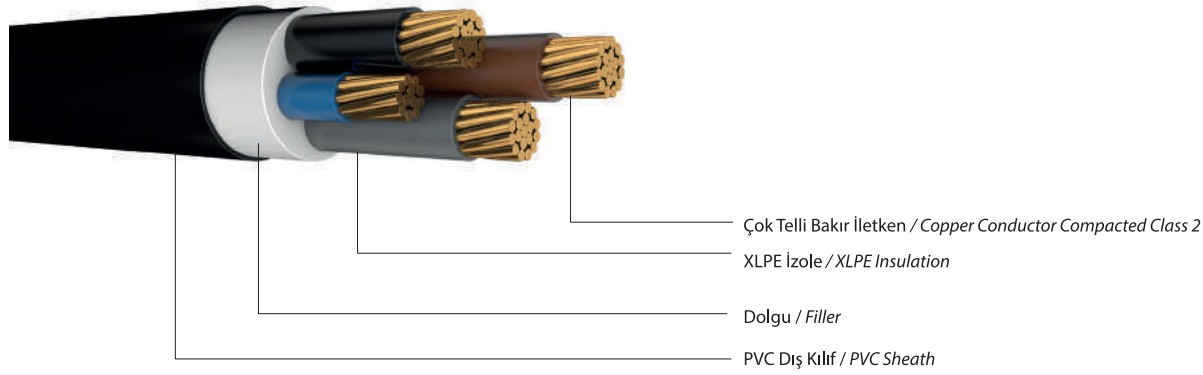

APPLICATION:

Indoor or outdoor installations, where there is no mechanical damage risk.
Maximum continuous normal operating temperature: 90 °C
Maximum short circuit temperature: 250 °C
Standard: IEC 60502-1
Power cables with extruded insulation
Cables for rated voltages of 1 kV (Um = 1,2 kV)

KULLANIM ALANI:

Bina içi ve dışı elektrik tesisatlarında, mekanik darbe riski olmayan uygulamalarda
En yüksek normal şartlarda sürekli çalışma sıcaklığı: 90 °C
En yüksek kısa devre akımında çalışma sıcaklığı: 250 °C
Standart: IEC 60502-1
Kablolar - Beyan Gerilimi 1 kV (Um=1,2 kV) olan kablolar

Electrical and Mechanical Properties – Round Conductors (N)2XY-RM 4 CORE

No. X nominal area of the conductors / İletkenlerin sayısı ve anma kesit alanı	Min. no. of wires in phase conductor / Faz İletkeni için En Düşük Tel Sayısı	Nominal insulation thickness / Nominal İzole Kalınlığı	Nominal outer sheath thickness / Nominal Dış Kılıf Kalınlığı	Overall diameter of Bundled (approx.) / Kablo Bükülü Dış Çapı (Yaklaşık)	Cable Unit Weight (approx.) / Kablo Birim Ağırlığı (Yaklaşık)	DC resistance @ 20°C / DC Elektrik Direnci 20°C'de	"Current Carrying Capacity / Akım Taşıma Kapasitesi"	
							In Air / Havada	"Under Ground / Yer Altında"
No.* sqmm		mm	mm	mm	kg/km	Ω/km	A	A
4 conductors								
4x16	6	0,70	1,80	20,30	930	1,150	98	112
4x25	6	0,90	1,80	24,00	1370	0,727	133	145
4x35	6	0,90	1,80	26,60	1800	0,524	162	174
4x50	6	1,00	1,90	29,90	2490	0,387	197	206
4x70	12	1,10	2,10	35,30	3450	0,268	250	254
4x95	15	1,10	2,30	39,20	4500	0,193	308	305
4x120	18	1,20	2,40	43,80	5660	0,153	359	348
4x150	18	1,40	2,50	48,90	7050	0,124	412	392
4x185	30	1,60	2,70	54,00	8670	0,0991	475	444
4x240	34	1,70	2,90	60,50	11050	0,0754	564	517

*Aras Kablo has right to camend above values without declaring prior to change.

*Aras Kablo önceden haber vermeksizin yukarıdaki değerleri değiştirme hakkına sahiptir.

0,6/1 kV NYFGbY, MULTI CORE POWER CABLE WITH COPPER CONDUCTOR, PVC INSULATION, STEEL WIRE AND TAPE ARMOUR PVC JACKET

0,6/1 kV NYFGbY, Çok Damarlı Enerji Kablosu, Bakır İletkenli, PVC izoleli,
Çelik Tel ve Bant Zirhli, PVC Kılıflı

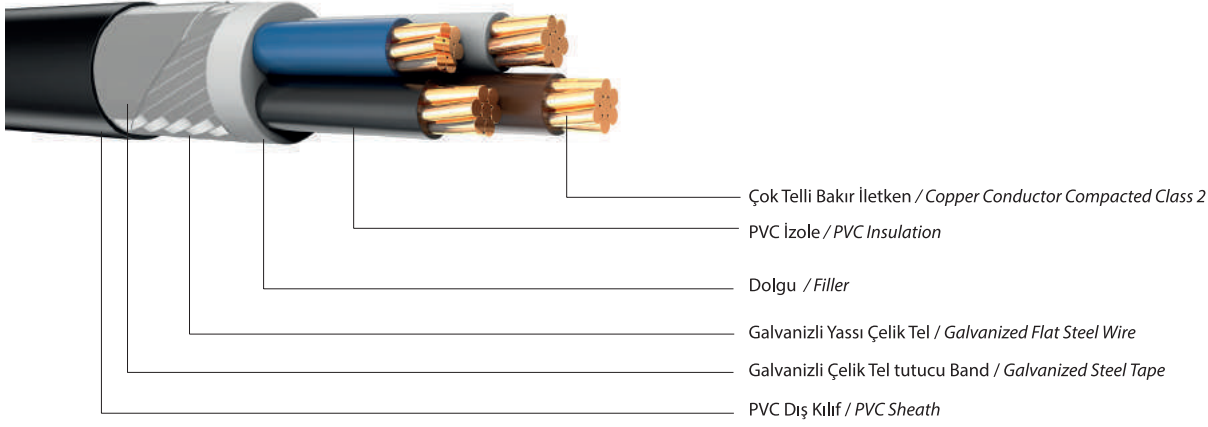

APPLICATION:

Indoor or outdoor installations, where there is no mechanical damage risk.
Maximum continuous normal operating temperature: 70 °C
Maximum short circuit temperature: 160 °C
Standard: IEC 60502-1
Power cables with extruded insulation
Cables for rated voltages of 1 kV (Um = 1,2 kV)

KULLANIM ALANI:

Bina içi ve dışı elektrik tesisatlarında, mekanik darbe riski olmayan uygulamalarda
En yüksek normal şartlarda sürekli çalışma sıcaklığı: 70 °C
En yüksek kısa devre akımında çalışma sıcaklığı: 160 °C
Standart: IEC 60502-1
Kablolar - Beyan Gerilimi 1 kV (Um=1,2 kV) olan kablolar

Electrical and Mechanical Properties – Round Conductors

(N)YFGbY-RM 3+1 CORE

No. X nominal area of the conductors / İletkenlerin sayısı ve anma kesit alanı	Min. no. of wires in phase conductor / Faz İletkeni için En Düşük Tel Sayısı	Nominal insulation thickness / Nominal İzole Kalınlığı	Nominal outer sheath thickness / Nominal Dış Kılıf Kalınlığı	Overall diameter of Bundled (approx.) / Kablo Bükülüşü Dış Çapı (Yaklaşık)	Cable Unit Weight (approx.) / Kablo Birim Ağırlığı (Yaklaşık)	DC resistance @ 20°C / DC Elektrik Direnci 20 °C'de	"Current Carrying Capacity / Akım Taşıma Kapasitesi"	
							In Air / Havada	"Under Ground / Yer Altında"
No.* sqmm		mm	mm	mm	kg/km	Ω/km	A	A
3+1 conductors								
3x25+16	6	1,20	2,00	27,50	2000	0,727	106	133
3x35+16	6	1,20	2,00	29,50	2400	0,524	129	159
3x50+25	6	1,40	2,10	33,50	3200	0,387	157	188
3x70+35	12	1,40	2,30	37,50	4100	0,268	199	232
3x95+50	15	1,60	2,40	42,00	5200	0,193	246	280
3x120+70	15	1,60	2,60	46,00	6400	0,153	285	318
3x150+70	15	1,80	2,70	50,00	7600	0,124	326	359
3x185+95	30	2,00	2,90	55,00	9350	0,0991	374	406
3x240+120	30	2,20	3,10	61,00	11500	0,0754	445	473

*Aras Kablo has right to camend above values without declaring prior to change.

*Aras Kablo önceden haber vermeksizin yukarıdaki değerleri değiştirme hakkına sahiptir.

0,6/1 kV NYFGbY, MULTI CORE POWER CABLE WITH COPPER CONDUCTOR, PVC INSULATION STEEL WIRE AND TAPE ARMOUR AND PVC JACKET

0,6/1 kV NYFGbY, Çok Damarlı Enerji Kablosu, Bakır İletkenli, PVC izoleli, Çelik Tel ve Bant Zırlı, PVC Kılıflı

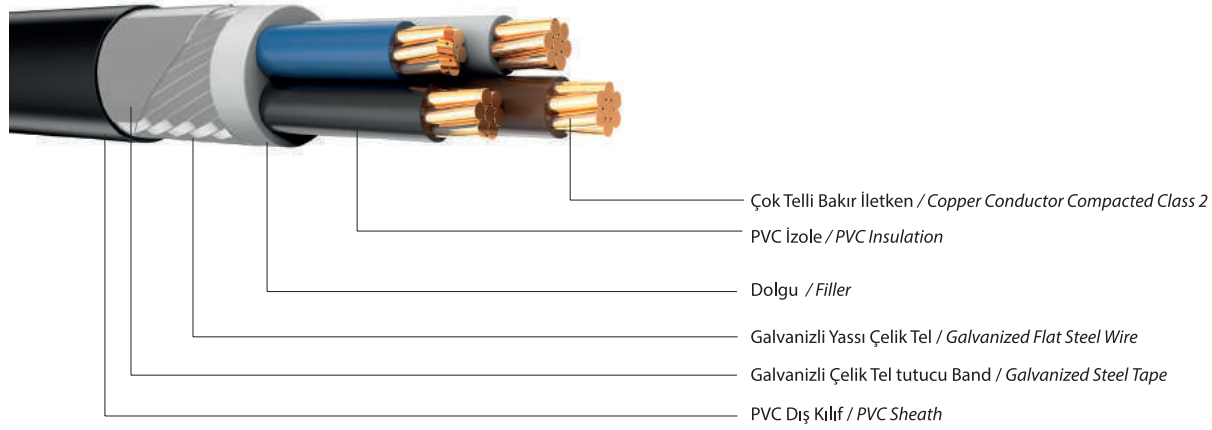

APPLICATION:

Indoor or outdoor installations, where there is no mechanical damage risk.
Maximum continuous normal operating temperature: 70 °C
Maximum short circuit temperature: 160 °C
Standard: IEC 60502-1
Power cables with extruded insulation
Cables for rated voltages of 1 kV (Um = 1,2 kV)

KULLANIM ALANI:

Bina içi ve dışı elektrik tesisatlarında, mekanik darbe riski olmayan uygulamalarda
En yüksek normal şartlarda sürekli çalışma sıcaklığı: 70 °C
En yüksek kısa devre akımında çalışma sıcaklığı: 160 °C
Standart: IEC 60502-1
Kablolar - Beyan Gerilimi 1 kV (Um=1,2 kV) olan kablolar

Electrical and Mechanical Properties – Round Conductors (N)YFGbY-RM 4 CORE

No. X nominal area of the conductors / İletkenlerin sayısı ve anma kesit alanı	Min. no. of wires in phase conductor / Faz İletkeni için En Düşük Tel Sayısı	Nominal insulation thickness / Nominal İzole Kalınlığı	Nominal outer sheath thickness / Nominal Dış Kılıf Kalınlığı	Overall diameter of Bundled (approx.) / Kablo Bükülü Dış Çapı (Yaklaşık)	Cable Unit Weight (approx.) / Kablo Birim Ağırlığı (Yaklaşık)	DC resistance @ 20°C / DC Elektrik Direnci 20 °C'de	"Current Carrying Capacity / Akım Taşıma Kapasitesi"	
							In Air / Havada	"Under Ground / Yer Altında"
No.* sqmm		mm	mm	mm	kg/km	Ω/km	A	A
4 conductors								
4x25	6	1,20	2,00	28,50	2100	0,727	106	133
4x35	6	1,20	2,10	31,00	2700	0,524	129	159
4x50	6	1,40	2,20	35,00	3500	0,387	157	188
4x70	12	1,40	2,40	40,00	4600	0,268	199	232
4x95	15	1,60	2,50	44,00	5800	0,193	246	280
4x120	15	1,60	2,70	48,00	7100	0,153	285	318
4x150	15	1,80	2,80	53,00	8600	0,124	326	359
4x185	30	2,00	3,00	58,60	10400	0,0991	374	406
4x240	30	2,20	3,20	65,30	13200	0,0754	445	473

*Aras Kablo has right to camend above values without declaring prior to change.

*Aras Kablo önceden haber vermeksizin yukarıdaki değerleri değiştirme hakkına sahiptir.

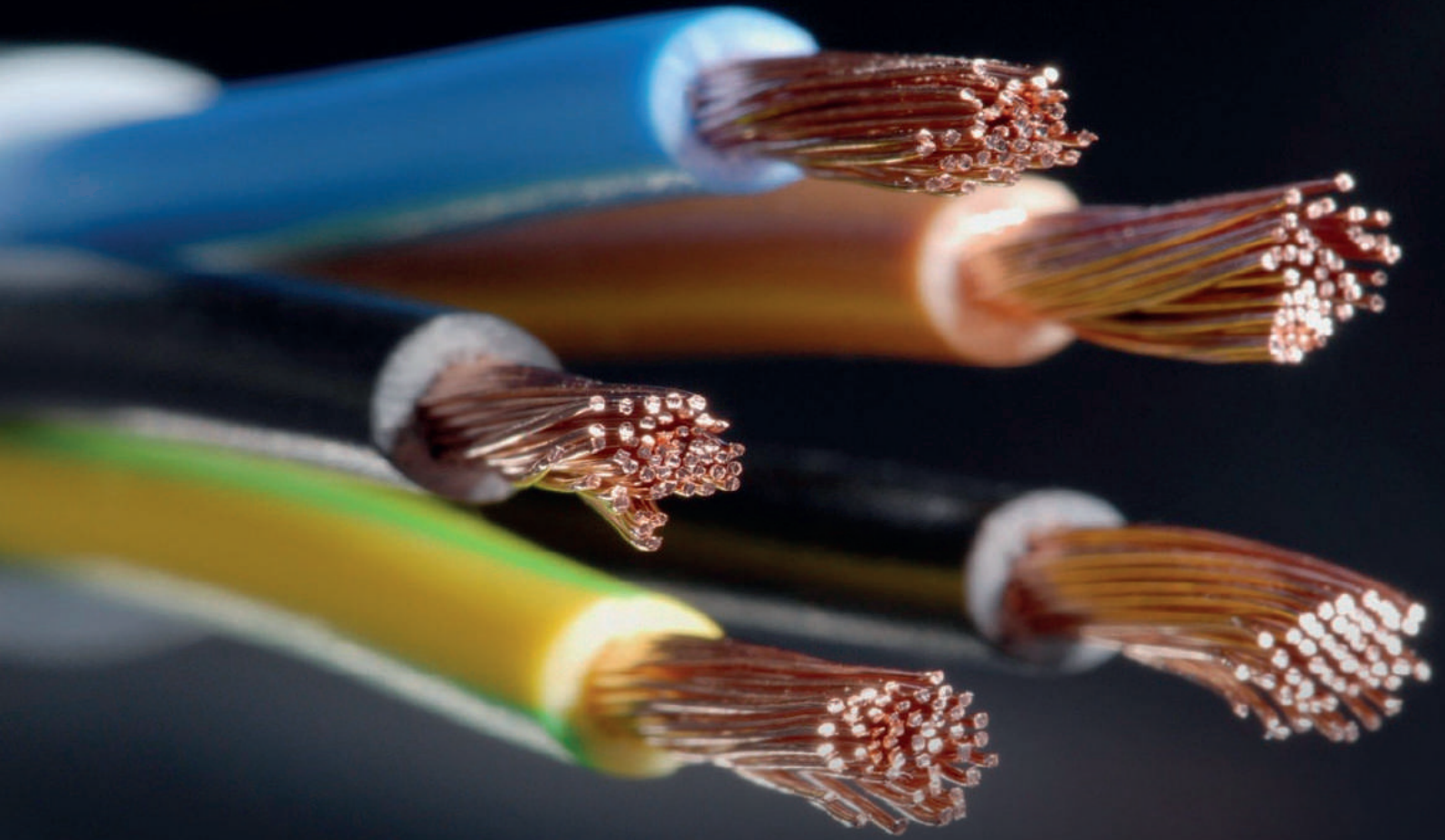

0,3/0,6 kV Cables

0,3/0,6 kV Kablolar

300/500-450/750 V NYA, SINGLE CORE POWER CABLE WITH COPPER CONDUCTOR, PVC INSULATION AND NO JACKET

300/500-450/750 V NYA, Tek Damarlı Enerji Kablosu, Bakır İletkenli, PVC İzoleli, Kılıfsız

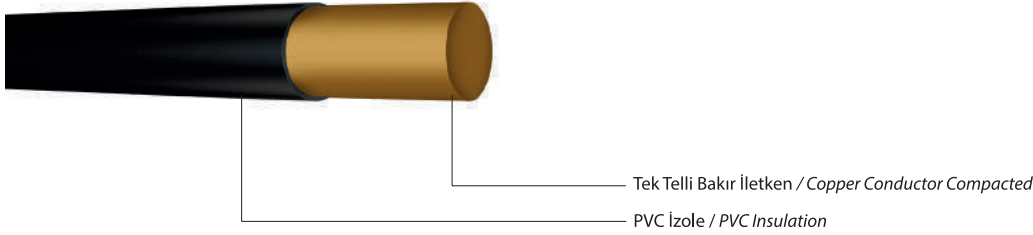

APPLICATION:

Used in active devices connections, covered, dry places, in distribution panels, on and under plaster as laid in conduit.
Maximum continuous normal operating temperature: 70 °C
Standard: TS EN 50525-2-31
Cables for rated voltages of 450/750V

KULLANIM ALANI:

Hareketli cihaz bağlantılarında, kapalı, kuru yerlerde, dağıtım panolarında, sıva altı ve sıva üstünde boru içinde kullanılırlar.
En yüksek normal şartlarda sürekli çalışma sıcaklığı: 70 °C
Standart: TS EN 50525-2-31
Kablolar - Beyan Gerilimi en çok 450/750V Olan Kablolar

Electrical and Mechanical Properties

(N)YA H05V-R, H05V-U, H07V-R, H07V-U - RE/RM

Nominal area of the conductors / İletkenlerin sayısı ve anma kesit alanı	Overall diameter (approx.) / Dış Çap (Yaklaşık)	Cable Unit Weight (approx.) / Kablo Birim Ağırlığı (Yaklaşık)	DC resistance @ 20°C / DC Elektrik Direnci 20 °C'de	"Current Carrying Capacity / Akım Taşıma Kapasitesi"		Delivery Length/ Sevk uzunluğu
				In Air / Havada	"Under Ground / Yer Altında	
No.* sqmm	mm	kg/km	Ω/km	A	A	m
0,5 RE	2,1	8	36	11	-	100
0,75 RE	2,2	11	24,5	15	-	100
1 RE	2,4	14	18,1	19	11	100
1,5 RE	2,8	21	12,1	24	15	100
2,5 RE	3,3	32	7,41	32	20	100
4 RE	3,8	46	4,61	42	25	100
6 RE	4,3	65	3,08	54	33	100
10 RE	5,6	108	1,83	73	45	100
10 RM	6,0	111	1,83	73	45	1000
16 RM	7,0	170	1,15	98	61	1000
25 RM	8,5	260	0,727	129	83	1000
35 RM	9,5	355	0,524	158	103	1000
50 RM	11,0	490	0,387	198	132	1000
70 RM	13,0	694	0,268	245	165	1000
95 RM	15,0	938	0,193	292	197	1000
120 RM	16,5	1172	0,153	344	235	1000
150 RM	18,0	1465	0,124	391	-	1000
185 RM	20,0	1808	0,0991	448	-	1000
240 RM	23,0	2343	0,0754	528	-	1000

*Aras Kablo has right to camend above values without declaring prior to change.
*Aras Kablo önceden haber vermeksizin yukarıdaki değerleri değiştirme hakkına sahiptir.

300/500-450/750 V NYAF, SINGLE CORE POWER CABLE WITH COPPER CONDUCTOR, PVC INSULATION AND NO JACKET

300/500-450/750 V NYAF, Tek Damarlı Enerji Kablosu, Bakır İletkenli, PVC izoleli, Kılıfsız



Çok Telli Bakır İletken / Copper Conductor Compacted Class 2

PVC İzole / PVC Insulation

APPLICATION:

Used in active devices connections, covered, dry places, in distribution panels, on and under plaster as laid in conduit.

Maximum continuous normal operating temperature: 70 °C

Standard: TS EN 50525-2-31

Cables for rated voltages of 450/750V

KULLANIM ALANI:

Hareketli cihaz bağlantılarında, kapalı, kuru yerlerde, dağıtım panolarında, sıva altı ve sıva üstünde boru içinde kullanılırlar.

En yüksek normal şartlarda sürekli çalışma sıcaklığı: 70 °C

Standart: TS EN 50525-2-31

Kablolar - Beyan Gerilimi en çok 450/750V Olan Kablolar

Electrical and Mechanical Properties

(N)YAF H05V-K, H07V-K

Nominal area of the conductors / İletkenlerin sayısı ve anma kesit alanı	Overall diameter (approx.) / Dış Çap (Yaklaşık)	Cable Unit Weight (approx.) / Kablo Birim Ağırlığı (Yaklaşık)	DC resistance @ 20°C / DC Elektrik Direnci 20 °C'de	"Current Carrying Capacity / Akım Taşıma Kapasitesi"		Delivery Length / Sevk uzunluğu
				In Air / Havada	"Under Ground / Yer Altında	
No.* sqmm	mm	kg/km	Ω/km	A	A	m
0,5	2,0	9	38	11	-	100
0,75	2,3	11	26	16	-	100
1	2,5	14	19,5	20	11	100
1,5	3,0	20	13,3	24	15	100
2,5	3,6	32	7,98	32	20	100
4	4,2	46	4,95	42	25	100
6	4,8	65	3,3	54	33	100
10	6,5	115	1,91	73	45	1000
16	8,0	175	1,21	98	61	1000
25	10,0	270	0,78	129	83	1000
35	11,0	350	0,554	158	103	1000
50	13,5	525	0,386	198	132	1000
70	15,0	700	0,272	245	165	1000
95	17,5	900	0,206	292	197	1000
120	19,5	1200	0,161	344	235	1000
150	22,0	1500	0,129	391	-	1000
185	24,0	1860	0,106	448	-	1000
240	27,5	2400	0,0801	528	-	1000

*Aras Kablo has right to camend above values without declaring prior to change.

*Aras Kablo önceden haber vermeksizin yukarıdaki değerleri değiştirme hakkına sahiptir.

300/500-450/750 V NYM, MULTIPLE CORE POWER CABLE WITH COPPER CONDUCTOR, PVC INSULATION AND PVC JACKET



300/500-450/750 V NYM (NVV), Çok Damarlı Enerji Kablosu, Bakır İletkenli, PVC izoleli, PVC Kılıflı

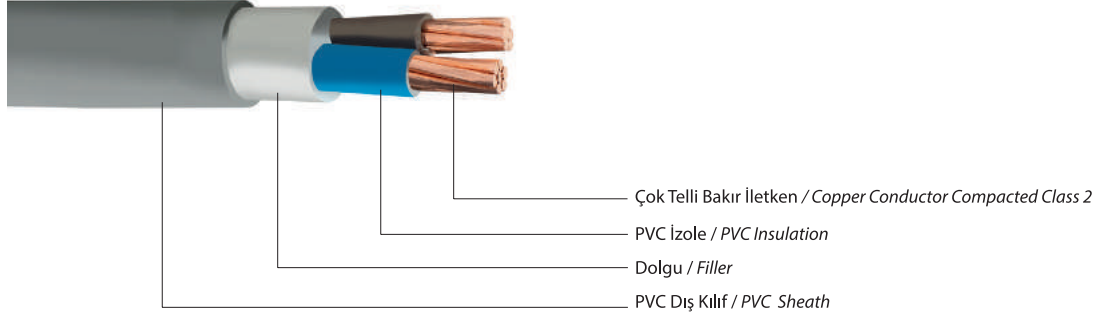

APPLICATION:

Used in wet and damp places without mechanical stress, in distribution panels, on and under plaster as laid in conduit or in fixed plants.
Maximum continuous normal operating temperature: 70 °C
Standard: TS EN 50525-2-31 TS HD 21.4 S2
Cables for rated voltages of 600 V (Um = 750 V)
Cables for rated voltages of 450/750V

KULLANIM ALANI:

Mekanik zorlamaların olmadığı rutubetli ve ıslak yerlerde, sıva altı ve sıva üstünde
boru içinde, sabit tesislerde kullanılırlar.
En yüksek normal şartlarda sürekli çalışma sıcaklığı: 70 °C
Standart: TS EN 50525-2-31 TS HD 21.4 S2
Kablolar - Anma gerilimi en çok 450/750V olan kablolar

Electrical and Mechanical Properties

(N)YM, NVV - RE/RM

Nominal area of the conductors / İletkenlerin sayısı ve anma kesit alanı	Overall diameter of Bundled (approx.) / Kablo Bükülü Dış Çapı (Yaklaşık)	Cable Unit Weight (approx.) / Kablo Birim Ağırlığı (Yaklaşık)	DC resistance @ 20°C / DC Elektrik Direnci 20 °C'de	"Current Carrying Capacity / Akım Taşıma Kapasitesi"		Delivery Length / Sevki Uzunluğu
				In Air / Havada	Under Ground / Yer Altında	
No.* sqmm	mm	kg/km	Ω/km	A	A	m
2 Core / 2 damarlı						
2x1,5 RE	10,1	183	12,1	22	32	1000
2x2,5 RE	10,8	186	7,41	30	42	1000
2x4 RE	12,6	263	4,61	40	54	1000
2x6 RE	13,0	322	3,08	51	68	1000
2x10 RM	15,1	441	1,83	70	90	1000
2x16 RM	16,9	601	1,15	94	116	1000
2x25 RM	21,2	964	0,727	119	150	1000
2x35 RM	22,9	1210	0,524	148	181	1000
3 Core / 3 damarlı						
3x1,5 RE	10,5	172	12,1	22	32	1000
3x2,5 RE	11,3	215	7,41	30	42	1000
3x4 RE	13,2	306	4,61	40	54	1000
3x6 RE	14,3	386	3,08	51	68	1000
3x10 RM	16,0	539	1,83	70	90	1000
3x16 RM	18,0	750	1,15	94	116	1000
3x25 RM	22,1	1175	0,727	119	150	1000
3x35 RM	24,4	1530	0,524	148	181	1000
4 Core / 4 damarlı						
4x1,5 RE	11,2	199	12,1	22	32	1000
4x2,5 RE	12,2	254	7,41	30	42	1000
4x4 RE	14,3	364	4,61	40	54	1000
4x6 RE	15,4	461	3,08	51	68	1000
4x10 RM	18,7	716	1,83	70	90	1000
4x16 RM	20,5	965	1,15	94	116	1000
4x25 RM	24,1	1455	0,727	119	150	1000
4x35 RM	27,1	1904	0,524	148	181	1000

300/300-300/500 V NYMH, MULTIPLE CORE POWER CABLE WITH COPPER CONDUCTOR, PVC INSULATION AND PVC JACKET

300/300-300/500 V NYMH, Çok Damarlı Enerji Kablosu, Bakır İletkenli, PVC izoleli, PVC Kılıflı

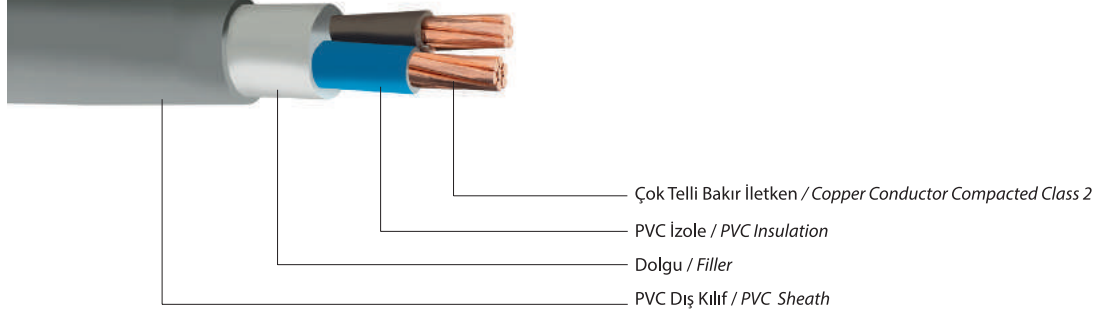

APPLICATION:

Used in covered, dry places with little mechanical enforcement, in distribution panels, on and under plaster as laid in conduit or in fixed plants.
Maximum continuous normal operating temperature: 70 °C
Standard: TS EN 50525-2-31 TS EN 50525-2-11
Cables for rated voltages of 600 V (Um = 750 V)

KULLANIM ALANI:

Az mekanik zorlamaların olduğu kapalı ve kuru yerlerde, sıva altı ve sıva üstünde boru içinde, sabit tesislerde kullanılırlar.
En yüksek normal şartlarda sürekli çalışma sıcaklığı: 70 °C
Standart: TS EN 50525-2-31 TS EN 50525-2-11
Kablolar - Beyan Gerilimi en çok 450/750 V olan kablolar

Electrical and Mechanical Properties

(N)YMH,(N)YMHY H03VV-F, H05VV-F

Nominal area of the conductors / İletkenlerin sayısı ve anma kesit alanı	Overall diameter of Bundled (approx.) / Kablo Bükülü Dış Çapı (Yaklaşık)	Cable Unit Weight (approx.) / Kablo Birim Ağırlığı (Yaklaşık)	DC resistance @ 20°C / DC Elektrik Direnci 20 °C'de	"Current Carrying Capacity" / Akım Taşıma Kapasitesi	Delivery Length / Sevki Uzunluğu
No.* sqmm	mm	kg/km	Ω/km	A	m
2 Core / 2 damarlı					
2x0,5	5,5	48	39	8	100
2x0,75	6,2	55	26	13	100
2x41	6,6	80	19,5	16	100
2x1,5	7,6	105	13,3	20	100
2x2,5	9,8	160	7,98	27	100
2x4	11	210	4,95	34	100
3 Core / 3 damarlı					
3x0,5	5,4	55	39	8	100
3x0,75	6,5	65	26	13	100
3x41	7,2	80	19,5	16	100
3x1,5	8,5	110	13,3	20	100
3x2,5	10	165	7,98	27	100
3x4	11,4	230	4,95	34	100
4 Core / 4 damarlı					
4x0,5	6,4	65	39	8	100
4x0,75	7,1	75	26	13	100
4x41	7,8	95	19,5	16	100
4x1,5	9,5	140	13,3	20	100
4x2,5	11	200	7,98	27	100
4x4	12,5	290	4,95	34	100
5 Core / 5 damarlı					
5x0,75	8	100	26	13	100
5x41	8,5	115	19,5	16	100
5x1,5	10,5	170	13,3	20	100
5x2,5	12,5	260	7,98	27	100
5x4	14,5	370	4,95	34	100



Aluminum Conductor

Alüminyum İletkenler



Tam Alüminyum İletkenler Teknik Özellikler

All Aluminium Conductor Technical Specifications

Related Standart / İlgili Standart : TS EN 50182 (TS IEC 61089)

AAC Allaluminum Conductorst GENERAL INFORMATION:

AAC conductors are composed of several wires stranded over each layer. All wires have same outer diameter. Most common AAC conductors are composed of 7, 19, 37 and 61 wires AAC conductors that are used for insulated cables as compacted will be composed of various number of wires.

APPLICATION:

- *Substation
- *Electricity Distribution Lines
- *Insulated Cables as Cable core

AAC Tam Alüminyum İletkenler GENEL BİLGİLER:

AAC iletkenler birden çok alüminyum telin birbiri üzerine bükülmesi ile üretilir. Bütün teller aynı çaptadır. Çogunlukla 7, 19, 37 ve 61 telden oluşur. İzoleli kablolarda kullanılan sıkıştırılmış AAC iletkenlerde tel adetleri farklılık arz edebilir.

KULLANIM ALANI:

- *Trafo Merkezleri
- *Elektrik Dağıtım Hatları
- *İzoleli Kablolar

CODE NUMBER ANMA DEĞERİ mm ²	CODE NUMBER ANMA DEĞERİ mm ²		CROSS SECTIONAL AREA KESİT ALANI		NUMBER and DIAMETER of WIRES TEL SAYISI ve ÇAPLARI		OVERALL DIAMETER KOMPLE İLETKEN ÇAPı mm	RATED BREAKING STRENGTH ANMA KOPMA YÜKÜ,	D.C. RESISTANCE 20 °C'de DOĞRU AKIM DİRENCİ Ohm/km	UNIT WEIGHT ANMA BİRİM AĞIRLIĞI Kg/km	CURRENT CARRYING CAPACITY AKIM TAŞIMA KAPASİTESİ (1) A
	CODE/KOD	SECTION KESİT AWG	TOTAL CONDUCTOR KOMPLE İLETKEN mm ²	COPPER EQUIVELANT BAKIR EŞDEĞERİ mm ²	NUMBER SAYI	DIAMETER ÇAP mm					
21	ROSE	4	21,1	13,3	7	2,0	5,9	416	1,356	58	104
27	LILY	3	26,6	16,7	7	2,2	6,6	514	1,078	73	124
34	IRIS	2	33,5	21,1	7	2,5	7,4	637	0,854	92	136
42	PANS	1	42,5	26,7	7	2,8	8,3	777	0,674	117	157
53	POPY	1\0	53,5	33,6	7	3,1	9,4	941	0,535	147	180
67	ASTER	2\0	67,1	42,2	7	3,5	10,5	1185	0,425	184	207
85	PHLOX	3\0	84,9	53,4	7	3,9	11,6	1435	0,337	233	237
107	OXLIP	4\0	107,4	67,5	7	4,4	13,3	1814	0,266	294	273
126	VALERIAN	250000	126,4	79,5	19	2,9	14,6	2261	0,228	348	305
135	DAISY	266800	135,3	85,1	19	3,0	15,1	2421	0,213	372	313
152	PEONY	300000	151,3	95,5	19	3,2	16,0	2671	0,190	418	340

AAC ASTM-B 231



Tam Alüminyum İletkenler Teknik Özellikler

All Aluminium Conductor Technical Specifications

Related Standart / İlgili Standart : ASTM - B 231

CODE	SIZE	STANDING N2xØmm	SECTION	OV. DIAMETER	Cable Weight	NOMINAL BREAKING LOAD	ELECTRICAL RESISTANCE			CURRENT CARRYING CAPACITY (1) A
							D.C. 20 °C W/km	A.C.		
KOD	AWG-MCM	mm	mm ²	mm	KG/KM	kN		C.C 25 °C W/km	C.C 75 °C W/km	
ROSE	4	7*1,96	21,1	5,9	58	3,92	1,364	1,391	1,666	145
IRIS	2	7*2,47	33,5	7,4	93	6,01	0,857	0,855	1,049	195
PANSY	1	7*2,78	42,5	8,3	117	7,30	0,680	0,694	0,831	225
POPY	1\0	7*3,12	53,5	9,4	148	8,86	0,539	0,550	0,659	260
ASTER	2\0	7*3,50	67,3	10,5	186	11,17	0,428	0,437	0,523	305
PHLOX	3\0	7*3,93	84,9	11,8	234	13,35	0,339	0,347	0,415	350
OXLIP	4\0	7*4,42	107,4	13,3	296	17,05	0,269	0,275	0,329	410
SNEEZEWORTH	250	7*4,80	127,6	14,4	349	20,12	0,227	0,232	0,278	455
VALERIAN	250	17*2,91	126,4	14,6	349	20,74	0,227	0,232	0,278	455
DAISY	266,8	7*4,96	135,3	14,9	328	21,50	0,213	0,218	0,261	475
LAUREL	266,8	19*3,01	135,2	15,1	328	22,12	0,213	0,218	0,261	475
PEONY	300	19*3,19	151,9	16,0	419	24,38	0,190	0,195	0,232	515
TULIP	336,4	19*3,38	170,9	16,9	470	27,37	0,169	0,173	0,208	555
DAFFODİL	350	19*3,45	177,6	17,3	489	28,45	0,163	0,167	0,200	565
CANNA	397,5	19*3,68	202,1	18,4	55	31,64	0,143	0,147	0,166	615
GOLDENTUFT	450	19*3,91	228,1	19,6	683	35,11	0,126	0,130	0,156	665
COSMOS	477	19*4,02	241,2	20,1	666	37,20	0,119	0,122	0,147	690
SYRINGA	500	37*2,95	241,0	20,2	666	38,67	0,119	0,122	0,147	690
ZINNIA	500	19*4,95	253,3	20,6	699	38,98	0,114	0,117	0,137	715
HYACINTH	556,5	37*2,95	252,9	20,7	690	40,54	0,114	0,177	0,137	715
DAHLIA	556,5	19*4,35	282,4	21,8	777	43,39	0,102	0,109	0,126	765
MISTLETOE		37*3,11	281,1	21,8	777	44,25	0,102	0,109	0,126	765
MEADOWSWEET	600	37*3,23	303,2	22,6	838	47,62	0,095	0,098	0,112	800
ORCHID	636	37*3,33	322,2	23,3	888	50,73	0,089	0,093	0,111	835
HEUCHERA	650	37*3,37	320,0	23,6	908	51,84	0,087	0,091	0,109	855
VERBANA	700	37*3,49	354,0	24,4	978	55,63	0,081	0,085	0,101	880
FLAG	700	61*2,72	354,5	24,5	978	57,42	0,081	0,083	0,098	900
VIOLET	715	37*3,53	362,1	24,7	1.000	56,96	0,080	0,083	0,098	900
NASTURIUM	715,5	91,2,75	24,8	999,6	1.000	58,30	0,795	0,083	0,098	900



Tam Alüminyum İletkenler Teknik Özellikler

All Aluminium Conductor Technical Specifications

Related Standart / İlgili Standart : ASTM - B 231

CODE	SIZE	STANDING N2xØmm	SECTION	OV. DIAMETER	Cable Weight	NOMINAL BREAKING LOAD	ELECTRICAL RESISTANCE			CURRENT CARRYING CAPACITY (1) A
							D.C. 20 °C W/km	A.C.		
								C.C 25 °C W/km	C.C 75 °C W/km	
KOD	AWG-MCM	mm	mm ²	mm	KG/KM	kN				
PETUNNA	750	37*3,62	380,8	25,3	1048	58,30	0,076	0,079	0,094	922
CATTAIL	750	61*3,82	381,0	25,4	1048	60,08	0,076	0,079	0,094	922
ARBUTUIS	795	37*3,72	402,1	26,0	1111	61,86	0,072	0,075	0,089	960
LILAC	795	61*2,90	402,0	26,1	1111	63,65	0,072	0,075	0,089	960
FUCHSIA	800	37*3,75	408,7	26,3	1115	62,30	0,071	0,074	0,088	960
HELIOTROPE	800	61*2,92	408,7	26,3	1115	64,08	0,071	0,074	0,088	960
ANEMONE	874,5	37*3,91	444,3	27,4	1222	66,75	0,065	0,068	0,081	1020
CROCUS	874,5	61*3,04	444,3	27,4	1222	70,31	0,065	0,068	0,081	1020
COCKCOMB	900	37*3,96	455,7	27,7	1257	68,53	0,063	0,067	0,079	1040
SNAPDRAGON	900	61*3,09	457,4	27,8	1257	70,76	0,063	0,067	0,079	1040
MAHNOLIA	954	37*4,08	483,7	28,6	1333	1332,80	0,600	0,063	0,075	1080
GALDENGON	954	61*3,18	484,5	28,6	1333	75,22	0,060	0,063	0,075	1080
HAWKWEED	1000	37*4,17	505,3	29,2	1397	76,54	0,057	0,060	0,071	1110
CAMELLA	1000	61*3,25	506,0	29,3	1397	78,77	0,057	0,060	0,071	1110
BLUEBEL	1033,5	37*4,24	522,4	29,7	1444	78,77	0,055	0,058	0,069	1350
LARKSPUR	1033,5	61*3,31	524,9	29,8	1444	81,45	0,055	0,058	0,069	1350
MARIGOLD	1272	61*3,43	563,6	30,0	1555	87,67	0,051	0,055	0,064	1190
HAWTHORN	1192,5	61*3,55	603,8	32,0	1665	93,90	0,048	0,051	0,060	1240
NARCISSUS	1272	61*3,67	645,3	33,0	1777	97,90	0,045	0,048	0,057	1290
COLUMBINE	1351,5	61*3,78	684,5	34,0	1889	104,13	0,042	0,046	0,054	1340
CARNATION	1431	61*3,89	725,0	35,0	1999	108,14	0,398	0,043	0,051	1390
GADIOLUS	1510,5	61*4	766,5	36,0	2110	113,92	0,038	0,041	0,049	1430
COREOPSIS	15,9	61*4,10	805,4	36,9	2222	120,15	0,036	0,040	0,046	1480
JESSANINE	1750	61*4,30	885,8	38,7	2445	132,17	0,036	0,036	0,043	1565
COWSLIP	2000	91*3,76	1010,4	41,4	2793	152,19	0,028	0,033	0,038	1695
SAGEPRUS	2250	91*3,99	1137,8	43,9	3174	167,77	0,028	0,030	0,034	1810
PIGWEEED	2300	61*4,93	1164,4	44,4	3240	173,56	0,025	0,029	0,034	1830
LUPINE	2500	91*4,21	1266,8	46,3	3527	186,46	0,023	0,028	0,032	1920
BITTERROOT	2750	91*4,41	1390,0	48,5	3880	205,15	0,021	0,026	0,029	2020
TRILLIUM	3000	127*3,90	1517,0	50,7	4232	223,84	0,019	0,025	0,028	2120
BLUEBONNET	2500	127*4,22	1776,3	54,9	4985	261,22	0,017	0,022	0,025	2295

EN 50182 (AAC DIN 48201)



Tam Alüminyum İletkenler Teknik Özellikler

All Aluminium Conductor Technical Specifications

Related Standart / İlgili Standart : DIN 48201 (old code) EN 50182 (new code)

Code Kod	New Code Yeni Kod	SECTION KESİTİ mm ²	Composition Kompozisyon		Diameter Çap Overall mm	Rated Strength Mukavemet kN	Electrical Resistance Direnç Ω/km	Cable Weight Birim Ağırlığı Kg/km	Current Carrying Capacity 1(A)
			N°	Ømm					
16	16-AL1	15,89	7	1,70	5,1	2,84	1,802	43,4	110
25	24-AL1	24,25	7	2,10	6,3	4,17	1,181	66,3	145
35	34-AL1	34,46	7	2,50	7,5	5,74	0,833	93,9	180
50	49-AL1	49,48	7	3,00	9,0	7,95	0,579	135,2	225
50	48-AL1	48,36	19	1,80	9,0	8,44	0,595	132,9	225
70	66-AL1	65,82	19	2,10	10,5	11,25	0,437	180,9	270
95	93-AL1	93,27	19	2,50	12,5	15,65	1,309	256,3	340
120	117-AL1	117	19	2,80	14,0	18,75	0,246	321,5	390
150	147-AL1	147,1	37	2,25	15,7	25,25	0,196	405,7	455
185	182-AL1	181,6	37	2,50	17,5	30,45	0,159	500,9	520
240	243-AL1	242,5	61	2,25	20,2	39,35	0,119	871,1	625
300	299-AL1	299,4	61	2,50	22,5	47,55	0,097	828,5	710
400	400-AL1	400,1	61	2,89	26,0	60,70	0,072	1107,1	855
500	500-AL1	499,8	61	3,23	29,1	74,50	0,058	1382,9	990
625	626-AL1	626,3	91	2,96	32,6	95,00	0,046	1379,7	1140
800	802-AL1	802,1	91	3,35	36,8	118,20	0,036	2228,3	1340
1000	1000-AL1	999,7	91	3,74	41,1	145,50	0,029	2777,3	1540

*Aras Kablo has right to camend above values without declaring prior to change.

*Aras Kablo önceden haber vermeksizin yukarıdaki değerleri değiştirme hakkına sahiptir.



Tam Alüminyum İletkenler Teknik Özellikler

All Aluminium Conductor Technical Specifications

Related Standart / İlgili Standart : BS 215-Part1 (old code) EN 50182 (new code)

Code	New Code	Area	No. Of wires	Diameter		Mass per unit length	Rated strenght	DC Resistance	Current Carrying Capacity 1(A)
		mm ²		Wire Cond.	Cond.	kg/km			
				mm	mm				
MIDGE	23-AL1	23,3	7	2,1	6,2	64	4,20	1,224	167
GNAT	27-AL1	26,9	7	2,2	6,6	73	4,83	1,064	182
MOSQUITO	37-AL1	36,9	7	2,6	7,8	101	6,27	0,774	222
LADYBIRD	43-AL1	42,8	7	2,8	8,4	117	7,28	0,667	244
ANT	53-AL1	52,8	7	3,1	9,3	144	8,72	0,54	278
FLY	64-AL1	63,6	7	3,4	10,2	174	10,49	0,449	311
BLUEBOTTLE	74-AL1	73,6	7	3,7	11,0	201	11,78	0,388	342
EARWIG	79-AL1	78,6	7	3,8	11,3	215	12,57	0,363	356
GRASSHOPPER	84-AL1	84,1	7	3,9	11,7	230	13,45	0,34	370
CLEGG	96-AL1	95,6	7	4,2	12,5	261	15,30	0,298	401
WASP	106-AL1	106	7	4,4	13,2	290	6,95	0,269	428
BEETLE	106-AL1	106,4	19	2,7	13,4	292	18,08	0,27	429
BEE	132-AL1	132	7	4,9	14,7	361	21,12	0,216	491
HORNET	158-AL1	157,6	19	3,3	16,3	433	26,01	0,182	548
CATERPILLAR	186-AL1	185,9	19	3,5	17,7	511	29,75	0,154	608
CHAFER	213-AL1	213,2	19	3,8	18,9	586	34,12	0,134	662
SPIDER	238-AL1	237,6	19	4,0	20,0	653	38,01	0,121	708
COCKROACH	266-AL1	265,7	19	4,2	21,1	730	42,52	0,108	759
BUTTERFLY	323-AL1	322,7	19	4,7	23,3	887	51,63	0,089	857
MOTH	373-AL1	373,1	19	5,0	25,0	1025	59,69	0,077	939
DRONE	372-AL1	372,4	37	3,6	25,1	1027	59,69	0,077	938
CETIPEDE	415-AL1	415,2	37	3,8	26,5	1145	66,43	0,069	1004
MAYBUG	486-AL1	486,1	37	4,1	28,6	1341	77,78	0,059	1108
SCORPION	530-AL1	529,8	37	4,3	29,9	1461	84,77	0,054	1170
CICADA	628-AL1	628,3	37	4,7	32,6	1733	100,54	0,045	1302

*Aras Kablo has right to camend above values without declaring prior to change.
*Aras Kablo önceden haber vermeksizin yukarıdaki değerleri değiştirme hakkına sahiptir.

EN 50182 (AAC UNE 21018) / SPAIN



Tam Alüminyum İletkenler Teknik Özellikler

All Aluminium Conductor Technical Specifications

Related Standart / İlgili Standart : UNE 21018 (old code) EN 50182 (new code)

“Characteristics of aluminium conductors used in Spain - Type AL1”

Code Kod	New Code Yeni Kod	SECTION KESİT mm ²	Composition Kompozisyon		Diameter Çap Overall mm	Rated Strength Mükavemet kN	Electrical D.C. Resistance Direnc Ω/km	Cable Weight Birim Ağırlığı Kg/km	Current Carrying Capacity I(A)
			No. Of Wires	Diameter mm					
L-28	28-AL1	27,8	7	2,3	6,8	5,01	1,0268	76	187
L-40	43-AL1	43,1	7	2,8	8,4	7,33	0,6630	118	245
L-46	55-AL1	54,6	7	3,2	9,5	9,00	0,5239	149	284
L-80	76-AL1	75,5	19	2,3	11,4	13,60	0,3804	208	348
L-110	117-AL1	117	19	2,8	14,0	19,89	0,2456	322	456
L-145	148-AL1	148,1	19	3,2	15,8	24,43	0,1941	407	528
L-180	188-AL1	188,1	19	3,6	17,8	30,09	0,1528	517	613
L-280	279-AL1	279,3	37	3,1	21,7	46,08	0,1038	770	782
L-400	301-AL1	381,4	61	2,8	25,4	64,77	0,0759	1053	951
L-450	454-AL1	454,5	61	3,1	27,7	74,99	0,0639	1256	1060
L-550	547-AL1	547,3	61	0,4	30,4	90,30	0,0529	1512	1192
L-630	638-AL1	638,3	61	3,7	32,9	102,20	0,0453	1763	1315

Notes / Notlar :

- Direction of lay of external layer is right-hand (Z)

*Aras Kablo has right to camend above values without declaring prior to change.

*Aras Kablo önceden haber vermeksizin yukarıdaki değerleri değiştirme hakkına sahiptir.



Tam Alüminyum İletkenler Teknik Özellikler

All Aluminium Conductor Technical Specifications

Related Standart / İlgili Standart : GOST / GOCT 839-80

“Characteristics of aluminium conductors used in Russia - A

Номинальное сечение, мм ² Nominal cross-section	Число и диаметр проводов NUMBER and DIAMETER of WIRES			Число и диаметр проводов NUMBER and DIAMETER of WIRES			Число и диаметр проводов NUMBER and DIAMETER of WIRES		
	проволок число number of wires	“Диаметр проволоки, мм Wire diameter	повивов число helix number	проволок число number of wires	“Диаметр проволоки, мм Wire diameter	повивов число helix number	проволок число number of wires	“Диаметр проволоки, мм Wire diameter	повивов число helix number
(4)	1	2,24	-	-	-	-	-	-	-
(6)	1	2,76	-	-	-	-	-	-	-
10	1	3,57	-	7	1,35	1	-	-	-
(16)	7	1,70	1	7	1,70	1	7	1,70	1
(25)	7	2,13	1	7	2,13	1	7	2,13	1
(35)	7	2,51	1	7	2,50	1	7	2,50	1
40	-	-	-	7	2,70	1	-	-	-
(50)	19	3,00	1	7	3,00	1	7	3,00	1
63	19	-	-	7	3,39	1	-	-	-
(70)	-	2,13	2	7	3,55	1	-	-	-
(95)	19	2,51	2	7	4,10	1	-	-	-
100	-	-	-	19	2,59	2	-	-	-
(120)	19	2,80	2	19	2,80	2	19	2,80	2
125	-	-	-	19	2,89	2	-	-	-
(150)	19	3,15	2	19	3,15	2	19	3,15	2
160	-	-	-	19	3,27	2	-	-	-
(185)	37	2,51	3	19	3,50	2	19	3,50	2
200	-	-	-	19	3,66	2	-	-	-
(240)	37	2,84	3	19	4,00	2	-	-	-
250	-	-	-	19	4,09	2	-	-	-
(300)	37	3,15	3	37	3,15	3	-	-	-
315	-	-	-	37	3,29	3	-	-	-
(350)	37	3,45	3	37	3,45	3	-	-	-
(400)	37	3,66	3	37	3,66	3	-	-	-
(450)	-	-	-	37	3,90	3	-	-	-

*Aras Kablo has right to camend above values without declaring prior to change.

*Aras Kablo önceden haber vermeksizin yukarıdaki değerleri deęiştirme hakkına sahiptir.

Çelik Özlü Alüminyum Alaşım İletkenler – AACSR

TS EN 50182, ASTM B-711, IEC 61089

Application:

1. Aluminum Alloy Conductor Steel Reinforced - AACSR (bare conductor) is galvanized steel core wrapped by single layer or multiple layers concentrically stranded Al-Mg-Si wires.
2. AACSR conductor is suitable for practical overhead transmission application, especially for conditions like large span in towers or heavy wire load from wind and ice which often happens in high altitude areas.

Özellikler:

Alüminyum iletkenler, "Örgülü Alüminyum İletkenler" ve "Çelik Özlü Alüminyum İletkenler" olmak üzere iki bölüme ayrılır. Alüminyum iletkenlerin üretiminde kullanılan teller, yüksek kalite filmaşinlerinden soğuk çekme metodu ile çatlak, ezik gibi kusurlar olmaksızın, sert veya tavlı olarak üretilir.

AACSR 15,2 mm KORUMA İLETKENİ (PROTECTION CONDUCTOR) (Çelik Özlü Alüminyum Alaşım İletkenli Toprak Teli) (Steel Core Aluminum Alloy Conductive Ground Teli)	
ÖZELLİKLER (FEATURES)	
İLETKEN ÇAPI mm - CONDUCTIVE DIAMETER	15,20 ± 0.3 mm
BİRİM AĞIRLIK kg/km - UNIT WEIGHT	638-663 kg/km
ÜST KAT ADIM ORANI - TOP STEP STEP RATE	10-14
ALT KAT ADIM ORANI - SUB-STEP STEP RATE	14-26
ALÜMİNYUM ALAŞIM TELLER (ALUMINUM ALLOY WIRE)	
TEL ÇAPI mm - WIRE DIAMETER	12 x 3.05 ± %1 mm
TEK TEL MUKAVEMETİ Mpa - ONE WIRE STRENGTH Mpa	295 Mpa Min.
KOPMA UZAMASI % - COMPLETE EXTENSION %	% 3.0 Min.
DİRENÇ nWm (20°C) - RESISTANCE	32.53 Max
İLETKENLİK % IACS - CONDUCTIVITY	53 Min.
ÇELİK ÖZ (STEEL ABSTRACT)	
TEL ÇAPI mm - WIRE DIAMETER	7 x 3.05 ± 0.04 mm
% MUKAVEMET Mpa - RESISTANCE	1240 Mpa Min.
TEK TEL MUKAVEMETİ Mpa - ONE WIRE STRENGTH Mpa	1340 Mpa Min.
KOPMA UZAMASI % - COMPLETE EXTENSION %	% 3.5 Min.
GALVANİZ MİKTARI g/m ² - GALVANIZE QUANTITY	260 Min.



Tam Alüminyum İletkenler Teknik Özellikler

All Aluminium Conductor Technical Specifications

Related Standart / İlgili Standart : BS 3242 (Old Code) EN 50182 (New Code)

AAAC All Aluminium Alloy Conductor GENERAL INFORMATION:

AAAC conductors are composed of several wires stranded over each layer. All wires have same outer diameter. Most common AAAC conductors are composed of 7, 19, 37 and 61 wires. AAAC conductors that are used for insulated cables as compacted will be composed of various number of wires.

APPLICATION:

- *Substation
- *Electricity Distribution Lines
- *Electricity Transmission Lines
- *0,6-1kV Overhead Bundled Insulated Aluminium Cables

AAAC Tam Alaşımli Alüminyum İletkenler GENEL BİLGİLER:

AAAC iletkenler birden çok alaşımli (Al-Mg-Si) tellerin birbiri üzerine bükülmesi ile üretilir. Bütün teller aynı çaptadır. 7, 19, 37, 61 ve 91 telden oluşur. AAAC iletkenler aynı zamanda 0,6-1 kV havai hat izoleli kablolarda askı teli olarak da kullanılır.

KULLANIM ALANI:

- *Trafo Merkezleri
- *Elektrik Dağıtım Hatları
- *Elektrik İletim hatları
- *0,6-1kV Havai Hat Bükülü İzoleli Kablo Askı Teli

“Characteristics of aluminium conductors used in the United Kingdom - Type AL3

CODE	Old Code	Area	No Of Wires	DIAMETER		Mass per Unit length	Rated Strength	DC Resistance	Current Carrying Capacity 1(A)
				Wire	Cond.				
		mm ²		mm	mm	kg/km	Kn	Ω/km	
19-AL3	BOX	18,8	7	1,85	5,6	51,4	5,55	1,748 0	138
24-AL3	ACACIA	23,8	7	2,08	6,2	64,9	7,02	1,382 8	160
30-AL3	ALMOND	30,1	7	2,34	7,0	82,2	8,88	1,092 6	185
42-AL3	CEDAR	35,5	7	2,54	7,6	96,8	10,46	0,927 3	205
48-AL3	DEODAR	42,2	7	2,77	8,3	115,2	12,44	0,7797	228
48-AL3	FIR	47,8	7	2,95	8,9	130,6	14,11	0,687 5	246
60-AL3	HAZEL	59,9	7	3,30	9,9	163,4	17,66	0,549 4	283
72-AL3	PINE	71,6	7	3,61	10,8	195,6	21,14	0,4591	316
84-AL3	HOLLY	84,1	7	3,91	11,7	229,5	24,79	0,3913	350
90-AL3	WILLOW	89,7	7	4,04	12,1	245	26,47	0,366 5	364
119-AL3	AOK	118,9	7	4,65	14,0	324,5	35,07	0,276 7	434
151-AL3	MULBERRY	150,9	19	3,18	15,9	414,3	44,52	0,2192	503
181-AL3	ASH	180,7	19	3,48	17,4	469,1	53,31	0,183 0	563
211-AL3	ELM	211,0	37	3,76	18,8	579,2	62,24	0,156 8	620
239-AL3	POPLAR	239,4	37	2,87	20,1	659,4	70,61	0,1387	671
303-AL3	SYCAMORE	303,2	37	3,23	22,6	835,2	89,4	0,1095	777
362-AL3	UPAS	362,1	37	3,53	24,7	997,5	106,32	0,091 7	870
479-AL3	YEW	479,0	37	4,06	28,4	1 319,6	141,31	0,069 3	1037
498-AL3	TOTARA	489,1	37	4,14	29,0	1 372,1	146,93	0,066 6	1062
587-AL3	RUBUS	586,9	61	3,50	31,5	1 622,0	173,13	0,056 7	1177
659-AL3	SORBUS	659,4	61	3,71	33,4	1 822,0	194,53	0,0505	1264
821-AL3	ARAUCARIA	821,1	61	4,14	37,3	2 269,4	242,24	0,040 6	1454
996-AL3	REDWOOD	996,2	61	4,56	41,0	2 753,2	293,88	0,0334	1639

NOTE Direction of lay of external layer is right-hand (Z)

*Aras Kablo has right to camend above values without declaring prior to change.
*Aras Kablo önceden haber vermeksizin yukarıdaki değerleri değiştirme hakkına sahiptir.



Tam Alüminyum İletkenler Teknik Özellikler

All Aluminium Conductor Technical Specifications

Related Standart / İlgili Standart : EN 50182 (New Code)

Characteristics of aluminium alloy conductors used in Spain – Type AL2

CODE	Old Code	Area	No Of Wires	DIAMETER		Mass per Unit length	Rated Strength	DC Resistance	Current Carrying Capacity 1(A)
				Wire	Cond.				
		mm ²		mm	mm	kg/km	Kn	Ω/km	
28-AL2	D 28	27,8	7	2,25	6,8	76,0	9,05	1,193 0	175
43-AL2	D 40	43,1	7	2,80	8,4	117,7	14,01	0,7704	230
55-AL2	D 56	54,6	7	3,15	9,5	148,9	17,73	0,6087	266
76-AL2	D 80	75,5	19	2,25	11,3	207,4	24,55	0,442	326
117-AL2	D 110	117,0	19	2,80	14,0	321,2	38,02	0,2854	428
148-AL2	D145	148,1	19	3,15	15,8	406,5	48,12	0,2255	496
188-AL2	D 180	188,1	19	3,55	17,8	516,3	59,24	0,1176	707
279-AL2	D 280	279,3	37	3,10	21,7	769,3	90,76	0,12	735
381-AL2	D 400	381,1	61	2,82	25,4	1 053,0	123,82	0,0882	892
454-AL2	D 450	454,5	61	3,08	27,7	1 256,1	147,71	0,074	996
547-AL2	D 550	547,3	61	3,38	30,4	1 512,7	177,88	0,0614	1119
638-AL2	D 630	638,3	61	3,65	32,9	1 764,0	201,06	0,0527	1233

NOTE Direction of lay of external layer is right-hand (Z)

Characteristics of aluminium alloy conductors used in Germany -Type AL3

CODE	Old Code	Area	No Of Wires	DIAMETER		Mass per Unit length	Rated Strength	DC Resistance	Final modulus of elasticity	Coefficient of linear expansion	Current Carrying Capacity
				Wire	Cond.						
		mm ²		mm	mm	kg/km	Kn	Ω/km	N/mm2	1/K	A
16-AL3	16	15,9	7	1,70	5,10	43,4	4,69	2,070 1	60 000	2,30-05	105
24-AL3	25	24,2	7	2,10	6,30	66,2	7,15	1,356 6	60 000	2,30-05	135
34-AL3	35	34,4	7	2,50	7,50	93,8	10,14	0,957 2	60 000	2,30-05	170
49-AL3	50	49,5	7	3,00	9,00	135,1	14,60	0,664 7	60 000	2,30-05	210
48-AL3	50	48,3	19	1,80	9,00	132,7	14,26	0,684 1	57 000	2,30-05	210
66-AL3	70	65,8	19	2,10	10,5	180,7	19,41	0,502 6	57 000	2,30-05	255
93-AL3	95	93,3	19	2,50	12,5	256,0	27,51	0,354 6	57 000	2,30-05	320
117-AL3	120	117,0	19	2,80	14,0	321,2	34,51	0,282 7	57 000	2,30-05	365
147-AL3	150	147,1	37	2,25	15,8	405,3	43,40	0,225 6	57 000	2,30-05	425
182-AL3	185	181,6	37	2,50	17,5	500,3	53,58	0,182 7	57 000	2,30-05	490
243-AL3	240	242,5	61	2,25	20,3	670,3	71,55	0,137 3	55 000	2,30-05	585
299-AL3	300	299,4	61	2,50	22,5	827,5	88,33	0,111 2	55 000	2,30-05	670
400-AL3	400	400,1	61	2,89	26,0	1 105,9	118,04	0,083 2	55 000	2,30-05	810
500-AL3	500	499,8	61	3,23	29,1	1 381,4	147,45	0,066 6	55 000	2,30-05	930
626-AL3	625	626,2	91	2,96	32,6	1 737,7	184,73	0,053 4	55 000	2,30-05	1 075
802-AL3	800	802,1	91	3,35	36,9	2 225,8	236,62	0,041 7	55 000	2,30-05	1 255
1000-AL3	1000	999,7	91	3,74	41,1	2 774,3	249,91	0,033 4	55 000	2,30-05	1 450

NOTE 1: Direction of lay of external layer is right-hand (Z)

NOTE 2: Values of final modulus of elasticity and coefficient of linear expansion for the conductor sizes listed in the Table are used in Germany. Values for other conductor constructions may be calculated using the method given in IEC 61597

NOTE 3: Guideline values of current carrying capacity are valid up to a frequency of 60 Hz, assuming a wind velocity of 0,6 m/s, the effect of solar initial ambient temperature of 35C and a conductor temperature of 80C. For special applications, when there is no air turbulence, the values should be reduced by 30 % radiation for Germany an

*Aras Kablo has right to camend above values without declaring prior to change.
*Aras Kablo önceden haber vermeksizin yukarıdaki değerleri değiştirme hakkına sahiptir.



Tam Alüminyum İletkenler Teknik Özellikler

All Aluminium Conductor Technical Specifications

Related Standart / İlgili Standart : ASTM B-232 IEC 61089

CODE	Cross Section mm ²		Stranding & wire diam	Overall diam.	Unit weight	Rated strength	Elect. resist. At 20 °C	Current Carrying Capacity I(A)
	Al equiv	Alloy						
ALTON	48,69	24,7	7x2,12	6,4	68	7,84	1,3576	162
AMES	77,47	39,3	7x2,67	8,0	108	12,40	0,8533	216
AZUSA	123,3	62,5	7x3,37	10,1	172	19,00	0,5364	288
ANAHEIM	155,4	78,7	7x3,78	11,4	217	24,00	0,4255	333
AMHERST	195,7	99,2	7x4,25	12,8	273	30,20	0,3379	384
ALLIANCE	246,9	125,1	7x4,77	14,3	345	38,10	0,2658	444
BUTTE	312,8	158,5	19x3,26	16,3	437	46,70	0,2114	516
CANTON	394,5	199,9	19x3,66	18,3	551	59,00	0,1675	596
CAIRO	465,4	235,8	19x3,98	19,9	650	69,60	0,1421	661
DARIEN	559,5	283,5	19x4,36	21,8	781	83,60	0,1181	741
ELGIN	652,4	330,6	19x4,71	23,5	911	97,50	0,1013	817
FLINT	740,8	375,4	37x3,59	25,2	1,035	108,00	0,0892	885
GREELEY	927,2	469,8	37x4,02	28,1	1,295	136,00	0,0712	1018

CODE	Cross Section mm ²		Stranding & wire diam	Overall diam.	Unit weight	Rated strength	Elect. resist. At 20 °C	Current Carrying Capacity I(A)
	Al equiv	N0xmm Alloy						
16	18,4	7x1,83	5,5	50	5,43	1,7896	136	
25	28,8	7x2,29	6,9	79	8,49	1,1453	180	
40	46	7x2,89	8,7	126	13,58	0,7158	241	
63	72,5	7x3,63	10,9	198	21,39	0,4545	319	
100	115	19x2,78	13,9	316	33,95	0,2877	426	
125	144	19x3,10	15,5	395	42,44	0,2302	489	
160	184	19x3,51	17,6	506	54,32	0,1798	518	
200	230	19x3,93	19,6	633	67,91	0,1439	597	
250	288	19x4,39	22,0	791	84,88	0,1151	685	
315	363	37x3,53	24,7	999	106,95	0,0916	794	
400	460	37x3,98	27,9	1268	135,81	0,0721	921	
450	518	37x4,22	29,6	1427	152,79	0,0641	992	
500	575	37x4,45	31,2	1586	169,76	0,0577	1059	
560	645	61x3,67	33,0	1778	190,14	0,0516	1137	
630	725	61x3,89	35,0	2001	213,9	0,0485	1225	
710	817	61x4,13	37,2	2255	241,07	0,0407	1449	
800	921	61x4,38	39,5	2541	271,62	0,0361	1562	
900	1036	91x3,81	41,8	2861	305,58	0,0321	1683	
1000	1151	91x4,01	44,1	3179	339,53	0,0289	1799	
1120	1289	91x4,25	46,7	3561	380,27	0,0258	1929	
1250	1439	91x4,49	49,4	3974	424,41	0,0231	2069	

*Aras Kablo has right to camend above values without declaring prior to change.

*Aras Kablo önceden haber vermeksizin yukarıdaki değerleri değıştirme hakkına sahiptir.

EN 50182 (AAAC NF C34-125)



Tam Alüminyum İletkenler Teknik Özellikler

All Aluminium Conductor Technical Specifications

Related Standart / İlgili Standart : NF C 34-125 (Old Code) EN 50182 (New Code)

CODE	Old Code	Area mm ²	No Of Wires	DIAMETER		Mass per Unit length kg/km	Rated Strength Kn	DC Resistance Ω/km	Final modulus of elasticity N/mm ²	Coefficient of linear expansion 1/K	Direction of lay of external layer	Current Carrying Capacity I(A)
				Wire mm	Cond. mm							
	ASTER											
22-AL4	22	22	7	2,00	6,00	60,0	7,15	1,498 9	62 000	2,30-E	S	152
34-AL4	34,4	34,4	7	2,50	7,50	93,8	11,17	0,959 3	62 000	2,30-E	S	201
55-AL4	54,6	54,6	7	3,15	9,45	148,9	17,73	0,604 2	62 000	2,30-E	S	267
76-AL4	75,5	75,5	19	2,25	11,3	207,4	24,55	0,438 8	60 000	2,30-E	S	327
117-AL4	117	117	19	2,80	14,0	321,2	38,02	0,283 8	60 000	2,30-E	S	429
148-AL4	148	148,1	19	3,15	15,8	406,5	48,12	0,223 9	60 000	2,30-E	S	497
182-AL4	181,6	181,6	37	2,50	17,5	500,3	59,03	0,183 1	57 000	2,30-E	S	564
228-AL4	228	227,8	37	2,80	19,6	627,6	74,04	0,146 0	57 000	2,30-E	S	650
288-AL4	288	288,3	37	3,15	22,1	794,3	93,71	0,115 4	57 000	2,30-E	S	754
366-AL4	366	366,2	37	3,55	24,9	1008,9	115,36	0,090 8	57 000	2,30-E	S	876
570-AL4	570	570,2	61	3,45	31,1	1576,0	185,33	0,058 5	54 000	2,30-E	S	1155
851-AL4	851	850,7	91	3,45	38,0	2360,7	276,47	0,039 4	52 000	2,30-E	S	1485
1144-AL4	1144	1 143,5	91	4,00	44,0	3173,4	360,22	0,029 3	52 000	2,30-E	S	1786
1596-AL4	1600	1 595,9	127	4,00	52,0	4427,5	502,72	0,021 0	50 000	2,30-E	S	2221

*Aras Kablo has right to camend above values without declaring prior to change.

*Aras Kablo önceden haber vermeksizin yukarıdaki değerleri değiştirme hakkına sahiptir.

Tip 1 / Case 1

Sadece çelik öz yağlı / Steel core only greased

Tip 2 / Case 2

Dış kat hariç bütün iletken yağlı / All the conductor is greased except the outer layer

Tip 3 / Case 3

Dış kat dahil bütün iletken yağlı / All the conductor is greased including the outer layer

Tip 4 / Case 4

Dış kat yüzeyi hariç bütün iletken yağlı / All the conductor is greased except the outer surface of the outer layer

Case 1 :

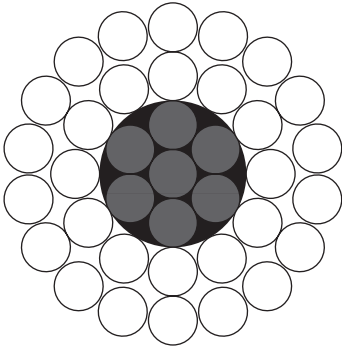

Case 2 :

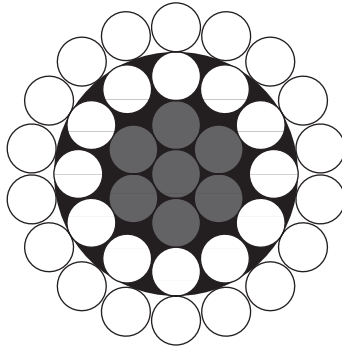

Case 3 :

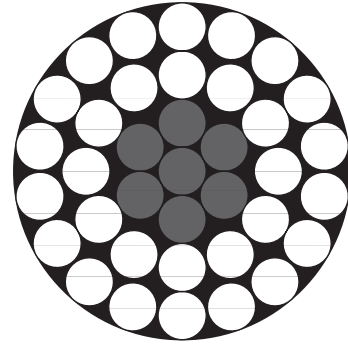

Case 4 :

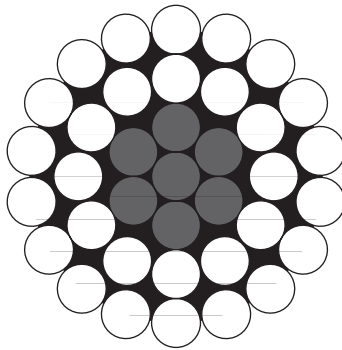

Elastisite Modülü Lineer Genleşme Katsayısı

Tam Alüminyum iletkenlerin Elastisite Modülü ve Lineer Genleşme Katsayıları IEC 207'a göre

Modulus of Elasticity and Coefficients of Linear Expansion for Constructions of All Aluminium Conductors to IEC Publ. No. 207

Tel Sayısı Number Of Wires	Elastisite Modülü Final Modulus of Elasticity		Lineer Genleşme Katsayısı Coefficient of Linear Expansion	
	Kg/mm ²	lb/in ²	1/C ^o	1/F ^o
Al				
7	6000	8,5x10 ⁶	23,0x10 ⁶	12,8x10 ⁶
19	5700	8,1x10 ⁶	23,0x10 ⁶	12,8x10 ⁶
37	5700	8,1x10 ⁶	23,0x10 ⁶	12,8x10 ⁶
61	5500	7,8x10 ⁶	23,0x10 ⁶	12,8x10 ⁶
91	5500	7,8x10 ⁶	23,0x10 ⁶	12,8x10 ⁶

Çelik Özlü Alüminyum iletkenlerin Elastisite Modülü ve Lineer Genleşme Katsayıları IEC 209'a göre

Modulus of Elasticity and Coefficients of Linear Expansion for Constructions of All Aluminium Conductors Steel-Reinforced to IEC Publ. No. 209

Tel Sayısı Number Of Wires		Elastisite Modülü Final Modulus of Elasticity		Lineer Genleşme Katsayısı Coefficient of Linear Expansion	
Al	St	Kg/mm ²	lb/in ²	1/C ^o	1/F ^o
6	1	8100	11,5x10 ⁶	19,1x10 ⁶	10,6 x10 ⁶
6	7	7700	11,0x10 ⁶	19,8x10 ⁶	11,0 x10 ⁶
12	7	10700	15,2x10 ⁶	15,3x10 ⁶	8,5 x10 ⁶
18	1	6700	9,5x10 ⁶	21,2x10 ⁶	11,8 x10 ⁶
24	7	7400	10,5x10 ⁶	19,6x10 ⁶	10,9 x10 ⁶
26	7	7700	10,9x10 ⁶	18,9x10 ⁶	10,5 x10 ⁶
28	7	7900	11,2x10 ⁶	18,4x10 ⁶	10,2 x10 ⁶
30	7	8200	11,6x10 ⁶	17,8x10 ⁶	9,9 x10 ⁶
30	19	8000	11,4x10 ⁶	18,0x10 ⁶	10,0 x10 ⁶
32	19	8200	11,7x10 ⁶	17,5x10 ⁶	9,7 x10 ⁶
54	7	7000	9,9x10 ⁶	19,3x10 ⁶	10,7 x10 ⁶
54	19	6800	9,7x10 ⁶	19,4x10 ⁶	10,8 x10 ⁶

* Aras Kablo has right to camend above values without declaring prior to change.
* Aras Kablo önceden haber vermeksizin yukarıdaki değerleri değiştirme hakkına sahiptir.

Tel Çapı (mm) Wire Diameter	Çap Toleransları Diameter Tolerance	Kesit (mm ²) Cross Section	Mukavemet (MPa) Rated Strength	Direnç D.C. (Ω / km) Electrical D.C. Resist- ance	Anma Birim Ağırlık (Kg / Km) Unit Weight
2,00	± 0,03 mm	3,14	187	9,00	8,48
2,50	± 0,03 mm	4,90	181	5,80	13,24
2,65	± 0,03 mm	5,51	179	5,10	14,89
3,00	± 0,03 mm	7,06	176	4,00	19,08
3,25	± % 1	8,29	173	3,40	22,40
3,50	± % 1	9,61	171	2,90	25,97
3,75	± % 1	11,03	170	2,60	29,81
4,00	± % 1	12,56	168	2,30	33,94
4,50	± % 1	15,89	165	1,80	42,95

- Alüminyum teller 2,00 - 4,50 mm arasında isteğe göre her çapta üretilir.
- Alüminyum tellerin 20°C'deki öz direnci 0,028264 Ω mm²/m
- Alüminyum tellerin yoğunluğu 2,703 g/cm³
- İletkenlik 61.0 IACS Min.

Ambalaj

Packaging Types



*Aras Kablo has right to camend above values without declaring prior to change.
*Aras Kablo önceden haber vermeksizin yukarıdaki değerleri değiştirme hakkına sahiptir.

Alüminyum Filmaşın



Material : Continuous Casting FC Grade Aluminium Wire Rod.

Technical Specifications :

Guaranteed chemical composition : EN AW 1370 (EAI 99,7)

Al%	IMPURITIES, % MAX										OTHER IMPURITIES, %	
	Fe	Si	Cu	Zn	Ti	V	Mn	Cr	Mg	B	Each	Total
Min 99,7	0,20	0,10	0,02	0,04	0,006	0,003	0,01	0,01	0,02	0,005	0,005	0,01

Dimensions, linear mass:

The primary, Aluminium Wire will be delivered in following diameter and unit weight range

Nominal diameter, [mm]	Deviation range (mm)	Linear mass [kg/m]
9,5	± 0,5	0,191
12,0	± 0,5	0,305

The linear mass is calculated for the density of 2,7 kg/dm³.

The cross-section of the wire rod is similar to a circle section, with three flattened sides. Wire ovality (the difference between the large and small dimensions of a section) will not exceed the value of the deviation range in table no.2

Mechanical and electric characteristics:

Alloy denomination	Metallurgical delivery state	Mechanical characteristics			Electric characteristics temperature : 20°C	
		R _m Mpa		Usual Elongation A ₁₀₀ %	Resistivity µcm max.	Conductivity %IACS min.
		Min	Max			
EN AW 1370 (EAL 99,7)	H 16	120	140	10	2,801	61,55
	H 14	115	130	14	2,801	61,55
	H13	105	120	16	2,801	61,55
	H 12	95	110	20	2,801	61,55
	H 11	80	95	25	2,785	61,90

*Aras Kablo has right to camend above values without declaring prior to change.

*Aras Kablo önceden haber vermeksizin yukarıdaki değerleri değiştirme hakkına sahiptir.

Material :

Continuous Casting 6101 T4 Almetec Grade Aluminium Wire Rod.

Technical Specifications :

Guaranteed chemical composition : EN 1715

Chemical Compositing of Alloying Elements, % According to EN 573-3							OTHER IMPURITIES, %	
Si	Fe	Cu	Mn	Mg	Zn	B	Each	Total
0,30	0,10	0,05	0,05	0,35	0,01	0,003	0,03	0,1
0,60	0,30			0,60				

Dimensions, linear mass :

The 6101 Alloy Aluminium Wire will be delivered in following diameter and unit weight range

Nominal diameter, [mm]	Deviation range (mm)	Linear mass [kg/m]
9,5	± 0,5	0,191
12,0	± 0,5	0,305

The linear mass is calculated for the density of 2,7 kg/dm³.

The cross-section of the wire rod is similar to a circle section, with three flattened sides. Wire ovality (the difference between the large and small dimensions of a section) will not exceed the value of the deviation range in table no.2

Mechanical and electric characteristics:

Alloy denomination	Metallurgical delivery state	Mechanical characteristics		Electric characteristics temperature : 20°C	
		Tensile Strength Mpa Min	Usual Elongation A ₁₀₀ %	Resistivity µcm max	Conductivity %IACS max.
6101 T4	AlmgSi	150	20	3,45	51,29

Material :

Continuous Casting 6201 T4 Alloy Grade Aluminium Wire Rod.

Technical Specifications :

Guaranteed chemical composition : EN 1715

Chemical Compositing of Alloying Elements, % According to EN 573-3							OTHER IMPURITIES, %	
Si	Fe	Cu	Mn	Mg	Zn	B	Each	Total
0,50	0,5	0,1	0,03	0,60	0,03	0,01	0,03	0,1
0,90				0,90				

Dimensions, linear mass :

The 6201 Alloy Aluminium Wire will be delivered in following diameter and unit weight range

Nominal diameter, [mm]	Deviation range (mm)	Linear mass [kg/m]
9,5	± 0,5	0,191
12,0	± 0,5	0,305

The linear mass is calculated for the density of 2,7 kg/dm³.

The cross-section of the wire rod is similar to a circle section, with three flattened sides. Wire ovality (the difference between the large and small dimensions of a section) will not exceed the value of the deviation range in table no.2

Mechanical and electric characteristics:

Alloy denomination	Metallurgical delivery state	Mechanical characteristics		Electric characteristics temperature : 20°C	
		Tensile Strength Mpa Min	Usual Elongation A ₁₀₀ %	Resistivity µcm max	Conductivity %IACS max.
6201 T81	Almg0,7Si	160	21	3,55	49,74

*Aras Kablo has right to camend above values without declaring prior to change.
*Aras Kablo önceden haber vermeksizin yukarıdaki değerleri değiştirme hakkına sahiptir.

Alüminyum Filmaşın



Aspect:

The surface of the wire rod must present a specific luster. The surface must be free of oxide, oil, seams, crack, films, pipes or spall. Isolated defects are allowed (scratches, bumps) provided that after their removal the wire rod stays within the variation range indicated in table no.2

MARKING :

Each coil will be provided with a tag where the following will Label

Material :	Diameter :
Net Weight :	Gross Weight :
Production Date :	Coil Number :
Customer Name :	Order No :

PACKING AND DELIVERY :

The wire rod is delivered in continuous wire coils of 1000-2500 kg.

The packing manner has to be mutually established with the customer, we are ensuring the following, according to options:

- 3 steel or plastic bands be 120°
- The coils are stacked on wooden racks, which allow the handling of the coil with the forklift
- The coils will be transported in closed containers, with transport options, respectively : on wagons or on road trucks. The coils will be placed on wooden stands.

Çelik Özlü Alüminyum İletken Teknik Özellikler

Aluminium Conductors Steel Reinforced Technical Specifications



ACSR Aluminum Conductors Steel reinforced

GENERAL INFORMATION:

ACSR conductors are composed of several aluminum and steel wires. Steel wires are always central and aluminum wires stranded over steel wire strands. Steel wires are galvanized (zinc coated), and mostly composed of 1, 7, 19 or 37 wires. Wire outer diameters of steel and aluminum will be same or different but all steel wires have same diameter as well aluminum wires have same diameter. Function of galvanized steel wires is suspension of conductor on the line.

APPLICATION:

- *Substation
- *Electricity Distribution Lines
- *Electricity Transmission Lines

ACSR Çelik Özlü alüminyum İletkenler

GENEL BİLGİLER:

ACSR iletkenler birden çok alüminyum ve galvaniz kaplı çelik tellerin merkezde çelik teller olacak şekilde birbiri üzerine bükülmesi ile üretilir. Galvanizli çelik teller merkezde bükülü olarak bulunur ve 1, 7, 19 veya 37 den oluşur. Çelik tel alüminyum tellerin dış çapları çoğunlukla aynıdır ancak çelik tel alüminyum tel çapları farklılık arz edebilir. Çelik özün görevi iletken için taşıyıcı fonksiyonda olmalıdır.

KULLANIM ALANI:

- *Trafo Merkezleri
- *Elektrik Dağıtım Hatları
- *Elektrik İletim Hatları

Code Number Anma Değeri	Canadian Standard Kanada Standartındaki		Section Kesit				Dia and no of Wires / Tel Sayı ve Çapları				Overall Diameter Anma Çapı		Rated Strength Anma Kopma Yüğü Kg	D.C. Resistance 20 °C Doğru Akım Direnci, Ohm/km	Unit Weight Anma Birim Ağırlığı			Total Weight Ağırlık	
	Type Adı	Section Kesit AWG	Al mm ²	Steel Çelik mm ²	Total Toplam mm ²	Copper Equivalent Bakır Eşdeğeri mm ²	Aluminium / Alüminyum		Steel / Çelik		Steel Core Çelik Öz mm	Total Toplam iletken mm			Al kg/Km	Steel Çelik Kg/Km	Total Toplam Kg/Km	Al %	Steel Çelik %
							No Of Wires Tel Sayısı	Wire Diameter Tel Çapı mm	No Of Wires Tel Sayısı	Wire Diameter Tel Çapı mm									
17\3	Tuhus	5	16,83	2,8	19,63	10,6	6	1,89	1	1,89	1,89	5,67	655	1,075	46	22	68	67,9	32,1
21\4	Swan	4	21,18	3,53	24,71	13,3	6	2,12	1	2,12	2,12	6,36	831	1,355	58	28	86	67,9	32,1
27\4	Swallow	3	26,69	4,45	31,14	16,8	6	2,38	1	2,38	2,38	7,14	1023	1,074	73	35	108	67,9	32,1
34\6	Sparrow	2	33,59	5,6	39,19	21,1	6	2,67	1	2,67	2,67	8,01	1264	0,854	92	44	136	67,9	32,1
42\7	Robin	1	42,41	7,07	49,48	26,7	6	3,00	1	3,00	3,00	9,00	1579	0,677	116	55	171	67,9	32,1
54\9	Rawen	1\0	53,52	8,92	62,44	33,7	6	3,37	1	3,37	3,37	10,11	1945	0,536	147	69	216	67,9	32,1
67\11	Quail	2\0	67,33	11,22	78,55	43,3	6	3,78	1	3,78	3,78	11,34	2420	0,426	185	87	272	67,9	32,1
85\14	Pigeon	3\0	85,12	14,18	99,3	53,5	6	4,25	1	4,25	4,25	12,75	3035	0,337	234	110	344	67,9	32,1
135\7	Waxwing	266800	134,98	7,5	142,48	84,9	18	3,09	1	3,09	3,09	15,45	3220	0,213	372	58	430	86,4	13,6
135\22	Partridge	266800	134,87	21,99	156,86	84,8	26	2,57	7	2,00	6,00	16,28	5099	0,214	372	172	544	68,5	31,5
152\8	Pheobe	300000	152,09	8,45	160,54	95,6	18	3,28	1	3,28	3,28	16,40	3628	0,190	419	66	485	86,4	13,6
152\25	Ostrich	300000	152,19	24,71	174,9	65,7	26	2,73	7	2,12	6,36	17,28	5736	0,190	420	193	613	68,5	31,5
242\39	Hawk	477000	241,65	39,19	280,84	152	26	3,44	7	2,67	8,01	21,77	8798	0,120	667	306	973	68,5	31,5
403\65	Drake	795000	402,56	65,44	468	253,2	26	4,44	7	3,45	10,35	28,11	14165	0,072	1111	511	1622	68,5	31,5
485\63	Cardinal	954000	484,53	62,81	547,34	304,7	54	3,38	7	3,38	10,14	30,42	15589	0,060	1340	490	1830	73,2	26,8
654\82	Pheasant	127200	654,08	81,71	726,79	405,7	54	3,90	19	2,34	11,70	35,10	20383	0,045	1794	640	2434	73,6	26,4

*Aras Kablo has right to camend above values without declaring prior to change.
*Aras Kablo önceden haber vermeksizin yukarıdaki değerleri değiştirme hakkına sahiptir.

ASTM - B 232



Çelik Özlü Alüminyum İletken Teknik Özellikler

Aluminium Conductors Steel Reinforced Technical Specifications

Code Kod	Size AWG- MCM	Stranding N _s xØmm		Section mm ²		Diameter Çap mm Overall		Cable Weight Birim Ağırlığı kg/km			Rated Strength Kopma Mukavemeti kN	Electrical Resistance Direnc Ω/km			Current Carrying Capacity I (A)
		Aluminium Alüminyum	Steel Çelik	Total Toplam	Aluminium Alüminyum	Total Toplam	Core Çelik Öz	Total Toplam	Aluminium Alüminyum	Steel Çelik		D.C. 20°C	A.C. 25°C	A.C. 75°C	
Turkey	6	6x1,68	1x1,68	15,5	13,3	5,0	1,7	54	37	17	5,30	2,114	2,150	2,685	110
Swan	4	6x2,12	1x2,12	24,7	21,2	6,4	2,1	85	58	27	8,28	1,328	1,354	1,717	145
Swanate	4	7x1,96	1x2,61	26,5	21,1	6,5	2,6	100	58	42	10,50	1,131	1,339	1,738	145
Sparrow	2	6x2,67	1x2,67	39,2	33,6	8,0	2,7	136	92	44	12,68	0,834	0,853	1,108	195
Sparate	2	7x2,47	1x3,30	42,1	33,5	5,2	3,3	159	92	67	6,20	0,825	0,844	1,118	195
Robin	1	6x3,00	1x3,00	49,5	42,4	9,0	3,0	171	116	55	15,80	0,662	0,677	0,891	200
Raven	1/0	6x3,37	1x3,37	62,4	53,5	10,1	3,4	216	147	69	19,49	0,524	0,537	0,717	255
Quail	2/0	6x3,78	1x3,38	78,6	67,3	11,3	3,8	273	185	88	23,63	0,416	0,427	0,580	295
Pigeon	3/0	6x4,25	1x4,25	99,3	85,1	12,8	4,3	344	233	110	29,46	0,330	0,339	0,471	340
Penguin	4/0	6x4,77	1x4,77	125,1	107,2	14,3	4,8	433	294	139	37,16	0,261	0,270	0,383	390
Waxwing	266,8	18x3,09	1x3,09	142,5	135,0	15,5	3,1	432	373	59	30,62	0,212	0,217	0,260	480
Partridge	266,8	26x2,57	7x2,00	156,9	134,9	16,3	6,0	546	374	172	50,28	0,21	0,217	0,257	490
Orstrich	300	26x2,73	7x2,12	176,9	152,2	17,3	6,4	615	421	193	56,52	0,187	0,191	0,228	530
Merlin	336,4	18x3,47	1x3,47	179,7	170,2	17,4	3,5	543	470	74	38,36	0,168	0,172	0,206	560
Linnet	336,4	26x2,89	7x2,25	198,4	170,6	18,3	6,8	689	472	217	62,75	0,166	0,167	0,204	570
Oriole	336,4	30x2,69	7x2,69	210,3	170,5	18,8	8,1	784	473	311	76,98	0,165	0,169	0,202	575
Chickadee	397,5	18x3,77	1x3,77	212,1	200,9	18,9	3,8	643	556	87	44,23	0,122	0,146	0,174	620
Brant	397,5	24x3,22	7x2,18	227,7	201,6	19,6	6,5	762	558	204	64,97	0,142	0,145	0,173	630
Ibis	397,5	26x3,14	7x2,44	234,0	201,3	19,9	7,3	814	558	256	72,53	0,141	0,144	0,173	635
Lark	397,5	30x2,92	7x2,92	247,8	200,9	20,4	8,8	927	555	372	90,30	0,140	0,143	0,172	645
Palican	477	18x4,14	1x4,14	255,8	242,3	20,7	4,1	771	666	105	52,51	0,118	0,122	0,145	700
Flicker	477	24x3,58	7x2,39	278,0	241,6	21,2	7,2	915	670	245	76,54	0,118	0,121	0,144	710
Hawk	477	26x3,44	7x2,67	280,8	241,6	21,8	8,0	978	670	308	86,77	0,117	0,120	0,144	715
Hen	477	30x3,20	7x3,20	297,6	241,3	22,4	9,6	1112	671	441	105,91	0,117	0,119	0,143	725
Osprey	556,5	18x4,47	1x4,47	298,2	282,5	22,4	4,5	899	777	122	60,96	0,101	0,104	0,125	775
Parakeet	556,5	24x3,87	7x2,58	318,9	282,3	23,2	7,7	1067	782	285	88,11	0,101	0,104	0,124	785
Dove	556,5	26x3,72	7x2,89	328,5	282,6	23,6	6,7	1140	781	359	105,57	0,101	0,103	0,124	790
Eagle	556,5	27x3,30	7x3,46	347,9	282,1	24,3	1,4	1298	983	515	123,71	0,100	0,103	0,123	800
Peacock	605	24x4,03	7x2,69	345,9	306,1	24,2	8,1	1161	850	311	96,12	0,093	0,095	0,114	830
Squab	605	26x3,87	7x3,01	355,6	305,8	24,5	9,0	1240	850	390	108,13	0,093	0,095	0,114	835
Wooduck	605	30x3,61	7x3,61	378,8	307,1	25,3	10,8	1411	851	560	128,60	0,032	0,094	0,113	845
Teal	605	30x3,61	19x2,16	376,1	307,1	25,2	10,8	1399	852	547	135,50	0,092	0,094	0,0113	845
Kingbird	636	18x4,78	1x4,78	340,9	323,0	23,9	4,8	1027	887	140	69,83	0,089	0,092	0,109	845
Rook	636	24x4,14	7x2,76	365,0	323,1	24,8	8,3	1282	893	389	97,60	0,088	0,091	0,108	855
Grosbeak	636	26x3,97	7x3,09	374,4	321,8	25,2	9,3	1302	893	409	113,25	0,088	0,091	0,108	855
Scoter	636	30x3,70	7x3,70	397,9	322,6	25,9	11,1	1478	891	586	135,27	0,088	0,090	0,108	870
Egret	636	30x3,70	19x2,22	396,1	322,6	25,9	11,1	1470	895	575	140,17	0,088	0,899	0,108	870
Swift	636	36x3,38	1,3x38	332,0	323,0	23,7	3,6	958	888	70	61,41	0,089	0,186	0,109	845
Flamingo	666,6	24x4,23	7x2,82	381,0	337,3	25,4	8,5	1277	935	342	105,46	0,084	0,856	0,104	880
Gannet	666,6	26x4,07	7x3,16	393,2	338,3	25,8	9,5	1365	936	429	117,48	0,084	0,085	0,103	885



Çelik Özlü Alüminyum İletken Teknik Özellikler

Aluminium Conductors Steel Reinforced Technical Specifications

Code Kod	Size AWG- MCM	Stranding N'xØmm		Section mm ²		Diameter Çap mm Overall		Cable Weight Birim Ağırlığı kg/km			Rated Strength Kopma Mukavemeti kN	Electrical Resistance Direnc Ω/km			Current Carrying Capacity I (A)
		Aluminium Alüminyum	Steel Çelik	Total Toplam	Aluminium Alüminyum	Total Toplam	Core Çelik Öz	Total Toplam	Aluminium Alüminyum	Steel Çelik		D.C. 20°C	A.C. 25°C	A.C. 75°C	
Stilt	715,5	24x4,39	7x2,92	410,2	363,3	26,3	8,8	1372	1005	368	113,5	0,078	0,081	0,097	920
Starling	715,5	26x4,21	7x3,28	421,0	361,9	26,7	9,8	1466	1005	461	126,4	0,078	0,080	0,096	930
Redwing	715,5	30x3,92	19x2,35	444,5	362,1	27,4	11,8	1653	1007	646	154,0	0,078	0,080	0,095	940
Cuckod	795,0	24x4,62	7x3,08	454,5	402,3	27,7	9,2	1522	1115	407	124,2	0,071	0,073	0,087	985
Drake	795,0	26x4,44	7x3,45	468,0	402,6	28,1	10,4	1628	1116	512	140,2	0,071	0,073	0,087	995
Coot	795,0	36x3,77	1x3,77	413,1	401,9	26,4	3,8	1198	1110	88	74,8	0,072	0,074	0,088	975
Tern	795,0	45x3,38	7x2,25	431,6	403,8	27,0	6,8	1333	1116	217	98,3	0,071	0,074	0,088	970
Condor	795,0	54x3,08	7x3,08	454,5	402,3	27,7	9,2	1514	1116	408	125,5	0,071	0,073	0,087	975
Mallard	795,0	30x4,14	19x2,48	495,6	403,8	29,0	12,4	1838	1119	719	170,9	0,070	0,072	0,086	1005
Ruddy	900,0	45x3,59	7x2,40	487,2	455,5	28,7	7,2	1511	1264	247	108,6	0,062	0,065	0,077	1050
Canary	900,0	54x3,28	7x3,28	515,4	456,3	29,5	9,8	1725	1264	461	142,0	0,062	0,065	0,077	1055
Catbird	954,0	36x4,14	1x4,14	498,1	484,6	29,0	4,1	1438	1333	104	8,1	0,060	0,062	0,074	1095
Rail	954,0	45x3,70	7x2,47	517,3	483,8	29,6	7,4	1600	1333	260	115,3	0,059	0,062	0,074	1090
Cardinal	954,0	54x3,38	7x3,38	547,3	484,5	30,4	10,1	1829	1340	489	150,4	0,059	0,061	0,073	1095
Tanager	1,033,5	36x4,30	1x4,30	537,3	522,8	30,1	4,3	1557	1434	113	95,2	0,056	0,059	0,069	1130
Ortolan	1,033,5	45x3,85	7x2,57	560,2	523,9	30,8	7,7	1734	14510	283	123,3	0,055	0,057	0,068	1150
Curlew	1,033,5	54x3,52	7x3,52	593,6	525,5	31,7	10,6	1981	14510	529	162,9	0,054	0,057	0,068	1150
Bluejay	1,113,0	45x4,00	7x2,66	604,4	565,5	32,0	8,0	1872	1563	305	132,6	0,051	0,053	0,064	1125
Finch	1,113,0	54,365	19x2,19	636,6	565,0	32,9	11,0	2130	1570	560	174,0	0,051	0,053	0,063	1205
Bunting	1,192,5	45x4,14	7x2,76	647,7	605,8	33,1	8,3	2000	1674	326	142,4	0,048	0,050	0,059	1255
Grackle	1,192,5	54x3,77	19x2,27	679,7	602,8	34,0	11,4	2281	1687	600	186,5	0,047	0,050	0,059	1260
Skylark	1,272,0	36x4,78	1x4,78	664,0	646,0	33,5	4,8	1917	1777	140	117,5	0,045	0,048	0,056	1310
Bittern	1,272,0	45x4,27	7x2,85	489,1	644,4	34,2	8,6	2134	1786	384	151,7	0,045	0,047	0,056	1310
Pheasant	1,272,0	54x3,90	19x2,34	726,8	645,1	35,1	11,7	2433	1794	639	194,0	0,044	0,047	0,055	1310
Dipper	1,351,5	45x4,40	7x2,92	731,4	684,2	35,2	8,8	2267	1899	368	161,1	0,042	0,045	0,053	1360
Martin	1,351,5	54x4,02	19x2,41	772,1	685,4	36,2	12,1	2585	1906	679	206,0	0,042	0,044	0,052	1365
Bobolink	1,431,0	45x4,53	7x3,02	775,4	725,3	36,2	9,1	2400	2009	391	170,4	0,040	0,043	0,050	1410
Plover	1,431,0	54x4,14	19x2,48	818,7	726,9	37,2	12,4	2738	2019	719	218,5	0,039	0,042	0,050	1415
Nuthatch	1,510,5	45x4,65	7x3,10	817,0	764,2	37,2	9,3	2533	2121	412	178,4	0,037	0,040	0,048	1455
Parrot	1,510,5	54x4,25	19x2,55	863,1	766,1	38,3	12,8	2890	2131	759	230,1	0,037	0,040	0,047	1460
Lapwing	1,590,0	45x4,78	7x3,18	863,1	807,5	38,2	9,5	2667	2232	435	187,8	0,036	0,039	0,046	1505
Falcon	1,590,0	54x4,36	19x2,62	908,6	806,2	39,3	13,1	3042	2243	799	242,5	0,035	0,038	0,045	1510
Chukar	1,780,0	84x3,70	19x2,22	976,7	903,2	42,7	11,1	3087	2511	576	226,9	0,032	0,035	0,041	1620
Bluebird	2,156,0	84x4,07	19x2,44	1181,6	1092,8	44,8	12,2	3738	3040	697	268,3	0,026	0,030	0,034	1815
Kiwi	2,167,0	72x4,41	7x2,94	1147,3	1099,8	44,1	8,8	3427	3057	371	221,6	0,026	0,030	0,035	1795
Thrasher	2,312,8	76x4,43	19x2,09	12353,0	1711,4	45,8	1035,0	3761	3262	499	252,3	0,025	0,028	0,033	1875

ASTM - B 232



Çelik Özlü Alüminyum İletken Teknik Özellikler

Aluminium Conductors Steel Reinforced Technical Specifications

Code Kod	Size AWG- MCM	Stranding N ² xØmm		Section mm ²		Diameter Çap mm Overall		Cable Weight Birim Ağırlığı kg/km			Rated Strength Kopma Mukavemeti kN	Electrical Resistance Direnç Ω/km			Current Carrying Capacity I (A)
		Aluminium Alüminyum	Steel Çelik	Total Toplam	Aluminium Alüminyum	Total Toplam	Core Çelik Öz	Total Toplam	Aluminium Alüminyum	Steel Çelik		D.C. 20°C	A.C. 25°C	A.C. 75°C	
Grouse	80	8x2,54	1x4,24	54,7	40,5	9,3	4,2	222	112	110	23,14	0,680	0,696	0,963	200
Petrel	101,8	12x2,34	7x2,34	81,7	51,6	11,7	7,0	378	143	235	42,28	0,522	0,529	7835	250
Minorca	110,8	12x2,44	7x2,44	88,8	56,1	12,2	7,3	412	156	256	50,28	0,479	0,498	0,742	265
Leghorn	134,6	12x2,69	7x2,69	108,0	68,2	13,5	8,1	500	189	311	60,52	0,395	0,401	0,618	300
Gunea	159	12x2,92	7x2,92	127,2	80,4	14,6	8,8	591	223	367	68,08	0,334	0,340	0,537	330
Dotterel	176,9	12x3,08	7x3,08	141,6	89,4	15,4	9,3	657	248	408	76,78	0,300	0,308	0,492	350
Dorking	190,8	12x3,20	7x3,20	152,8	96,5	16,0	9,6	709	268	441	83,21	0,278	0,284	0,462	370
Brahma	203,2	16x2,86	19x2,48	194,6	102,8	18,1	12,4	1007	285	722	126,37	0,252	0,256	0,430	380
Cochin	211,3	12x3,37	7x3,37	169,5	107,0	16,9	10,1	785	297	488	92,11	0,251	0,256	0,425	390



Çelik Özlü Alüminyum İletken Teknik Özellikler

Aluminium Conductors Steel Reinforced Technical Specifications

Code	New Code	Crossectinal Area			No Of Wires		Wire Diameter		Diameter		Mass per unit lenght kg/km	Rated Strength kN	DC resistance Ω/km	Final modulus of elasticity N/mm ²	Coefficient of linear expansion 1/K	Current Carrying Capacity A
		Al	Steel	Total			Al	Steel	Core	Cond.						
		mm ²	mm ²	mm ²	Al	Steel	mm	mm	mm	mm						
16/2,5	15-AL1/3-ST1 A	15,3	2,5	17,8	6	1	1,8	1,8	1,8	5,4	62	5,80	1,876	81,000	0,0000192	105
25/4	24-AL1/4-ST1 A	23,9	4,0	27,8	6	1	2,3	2,3	2,3	6,8	96	8,95	1,201	81,000	0,0000192	140
35/6	34-AL1/6-ST1 A	34,4	5,7	40,1	6	1	2,7	2,7	2,7	8,1	139	12,37	0,834	81,000	0,0000192	170
44/32	44-AL1/32-ST1 A	44,0	31,7	75,6	14	7	2,0	2,4	2,4	11,2	369	44,24	0,657	110,000	0,000015	-
50/8	48-AL1/8-ST1 A	48,3	8,0	56,3	6	1	3,2	3,2	3,2	9,6	195	16,81	0,593	81,000	0,0000192	210
50/30	51-AL1/30-ST1 A	51,2	29,8	81,0	12	7	2,3	2,3	7,0	11,7	375	42,98	0,564	107,000	0,0000153	-
70/12	70-AL1/11-ST1 A	69,9	11,4	81,3	26	7	1,9	1,4	4,3	11,7	282	26,27	0,413	77,000	0,0000189	290
95/15	94-AL1/15-ST1 A	94,4	15,3	109,7	26	7	2,2	1,7	5,0	13,6	381	34,93	0,306	77,000	0,0000189	350
95/55	97-AL1/56-ST1 A	96,5	56,3	152,8	12	7	3,2	3,2	9,6	16,0	707	77,85	0,299	107,000	0,0000153	-
105/75	106-AL1/76-ST1 A	105,7	75,5	181,2	14	19	3,1	2,3	11,3	17,5	885	105,82	0,274	110,000	0,000015	-
120/20	122-AL1/20-ST1 A	121,6	19,8	141,4	26	7	2,4	1,9	5,7	15,5	491	44,50	0,237	77,000	0,0000189	410
120/70	122-AL1/71-ST1 A	122,1	71,3	193,4	12	7	3,6	3,6	10,8	18,0	895	97,92	0,236	107,000	0,0000153	-
125/30	128-AL1/30-ST1 A	127,9	29,8	157,8	30	7	2,3	2,3	7,0	16,3	587	56,41	0,226	82,000	0,0000178	425
150/25	149-AL1/24-ST1 A	148,9	24,2	173,1	26	7	2,7	2,1	6,3	17,1	601	53,67	0,194	77,000	0,0000189	470
170/40	172-AL1/40-ST1 A	171,8	40,1	211,8	30	7	2,7	2,7	8,1	18,9	788	74,89	0,168	82,000	0,0000178	520
185/30	184-AL1/30-ST1 A	183,8	29,8	213,6	26	7	3,0	2,3	7,0	19,0	741	65,27	0,157	77,000	0,0000189	535
210/35	209-AL1/34-ST1 A	209,1	34,1	243,2	26	7	3,2	2,5	7,5	20,3	844	73,36	0,138	77,000	0,0000189	590
210/50	212-AL1/49-ST1 A	212,1	49,5	261,5	30	7	3,0	3,0	9,0	21,0	973	92,46	0,136	82,000	0,0000178	610
230/30	231-AL1/30-ST1 A	130,9	29,8	260,8	24	7	3,5	2,3	7,0	21,0	871	72,13	0,125	74,000	0,0000196	630
240/40	243-AL1/39-ST1 A	243,1	39,5	282,5	26	7	3,5	2,7	8,0	21,8	980	85,12	0,118	77,000	0,0000189	645
265/35	264-AL1/34-ST1 A	263,7	34,1	297,7	24	7	3,7	2,5	7,5	22,4	994	81,04	0,109	74,000	0,0000196	680
300/50	304-AL1/49-ST1 A	304,3	49,5	353,7	26	7	3,9	3,0	9,0	24,4	1227	105,09	0,094	77,000	0,0000189	740
305/40	305-AL1/39-ST1 A	304,6	39,5	344,1	54	7	2,7	2,7	8,0	24,1	1151	96,80	0,094	70,000	0,0000193	740
340/30	339-AL1/30-ST1 A	339,3	29,8	369,1	48	7	3,0	2,3	7,0	25,0	1171	91,71	0,085	62,000	0,0000205	790
380/50	382-AL1/49-ST1 A	381,7	49,5	431,2	54	7	3,0	3,0	9,0	27,0	1443	121,30	0,075	70,000	0,0000193	840
385/35	386-AL1/34-ST1 A	386,0	34,1	420,1	48	7	3,2	2,5	7,5	26,7	1334	102,56	0,074	62,000	0,0000205	850
435/55	434-AL1/56-ST1 A	434,3	56,3	490,6	54	7	3,2	3,2	9,6	28,0	1641	133,59	0,066	70,000	0,0000193	900
450/40	449-AL1/39-ST1 A	448,7	39,5	488,2	48	7	3,5	2,7	8,0	28,7	1549	119,05	0,064	62,000	0,0000205	920
490/65	490-AL1/64-ST1 A	490,3	63,6	553,8	54	7	3,4	3,4	10,2	30,6	1853	150,81	0,059	70,000	0,0000193	960
495/35	494-AL1/34-ST1 A	494,4	34,1	528,4	45	7	3,7	2,5	7,5	29,9	1633	117,96	0,058	61,000	0,0000209	985
510/45	511-AL1/45-ST1 A	515,0	45,3	558,8	48	7	3,7	2,9	8,6	30,7	1765	133,31	0,056	62,000	0,0000205	995
550/70	550-AL1/71-ST1 A	549,7	71,3	620,9	54	7	3,6	3,6	10,8	32,4	2077	166,32	0,052	70,000	0,0000193	1020
560/50	562-AL1/49-ST1 A	561,7	49,5	611,2	48	7	3,9	3,0	9,0	32,2	1940	146,28	0,051	62,000	0,0000205	1040
570/40	571-AL1/39-ST1 A	571,2	39,5	610,6	45	7	4,0	2,7	8,0	32,2	1887	136,40	0,050	61,000	0,0000209	1050
650/45	653-AL1/45-ST1 A	653,5	45,3	698,8	45	7	4,3	2,9	8,6	34,4	2160	156,18	0,044	61,000	0,0000209	1120
680/85	679-AL1/86-ST1 A	678,6	86,0	764,5	54	19	4,0	2,4	12,0	36,0	2550	206,56	0,042	68,000	0,0000194	1150
1045/45	1046-AL1/45-ST1 A	1045,6	45,3	1090,9	72	7	4,3	2,9	8,6	43,0	3248	218,92	0,027	60,000	0,0000217	1580

EN 50182 (BS 215)



Çelik Özlü Alüminyum İletken Teknik Özellikler

Aluminium Conductors Steel Reinforced Technical Specifications

Code	New Code	Cross-sectional Area			No Of Wires		Wire Diameter		Diameter		Mass per unit length kg/km	Rated Strength kN	DC resistance Ω/km
		Al	Steel	Total			Al	Steel	Core	Cond.			
		mm ²	mm ²	mm ²	Al	Steel	mm	mm	mm	mm			
Mole	11-AL1/2 ST1 A	10,6	1,8	12,4	6	1	1,50	1,50	1,50	4,50	43	4,14	2,702
Squirrel	21-AL1/3 ST1 A	21,0	3,5	24,5	6	1	2,11	2,11	2,11	6,33	85	7,87	1,365
Gopher	26-AL1/4 ST1 A	26,2	4,4	30,6	6	1	2,36	2,36	2,36	7,08	106	9,58	1,091
Weasel	32-AL1/5 ST1 A	31,6	5,3	36,9	6	1	2,59	2,59	2,59	7,77	128	11,38	0,906
Fox	37-AL1/6 ST1 A	36,7	6,1	42,8	6	1	2,79	2,79	2,79	8,37	148	13,21	0,781
Ferret	42-AL1/7 ST1 A	42,4	7,1	49,5	6	1	3,00	3,00	3,00	9,00	171	15,27	0,675
Rabbit	53-AL1/9 ST1 A	52,9	8,8	61,7	6	1	3,35	3,35	3,35	10,10	214	18,42	0,541
Mink	63-AL1/11 ST1 A	63,1	10,5	73,6	6	1	3,66	3,66	3,66	11,00	255	21,67	0,454
Skunk	63-AL1/37 ST1 A	63,2	36,9	100,1	12	7	2,59	2,59	7,77	13,00	463	52,79	0,456
Beaver	75-AL1/13 ST1 A	75,0	12,5	87,5	6	1	3,99	3,99	3,99	12,00	303	25,76	0,382
Horse	73-AL1/43 ST1 A	73,4	42,8	116,2	12	7	2,79	2,79	8,37	14,00	537	61,26	0,393
Raccon	79-AL1/13 ST1 A	78,8	13,1	92,0	6	1	4,09	4,09	4,09	12,30	318	27,06	0,363
Otter	84-AL1/14 ST1 A	83,9	14,0	97,9	6	1	4,22	4,22	4,22	12,70	339	28,81	0,341
Cat	95-AL1/16 ST1 A	95,4	15,9	111,3	6	1	4,50	4,50	4,50	13,50	385	32,76	0,300
Hare	105-AL1/17 ST1 A	105,0	17,5	122,5	6	1	4,72	4,72	4,72	14,20	424	36,04	0,273
Dog	105-AL1/14 ST1 A	105,0	13,6	118,5	6	7	4,72	1,57	4,71	14,20	394	32,65	0,273
Coyote	132-AL1/20 ST1 A	131,7	20,1	151,8	26	7	2,54	1,91	5,73	15,90	521	45,86	0,219
Cougar	132-AL1/17 ST1 A	131,5	7,3	138,8	18	1	3,05	3,05	3,05	15,30	419	29,74	0,218
Tiger	131-AL1/31 ST1 A	131,2	30,6	161,9	30	7	2,36	2,36	7,08	16,50	602	57,87	0,220
Wolf	158-AL1/37 ST1 A	158,1	36,9	194,9	30	7	2,59	2,59	7,77	18,10	725	68,91	0,182
Dingo	159-AL1/9 ST1 A	158,7	8,8	167,5	18	1	3,35	3,35	3,35	16,80	505	35,87	0,181
Lynx	183-AL1/43 ST1 A	183,4	42,8	226,2	30	7	2,79	2,79	8,37	19,50	842	79,97	0,157
Caracal	184-AL1/10 ST1 A	184,2	10,2	194,5	18	1	3,61	3,61	3,61	18,10	587	40,74	0,156
Panther	212-AL1/49 ST1 A	212,1	49,5	261,5	30	7	3,00	3,00	9,00	21,00	973	92,46	0,136
Jaguar	211-AL1/12 ST1 A	210,6	11,7	222,3	18	1	3,86	3,86	3,86	19,30	671	46,57	0,136
Lion	238-AL1/56 ST1 A	238,3	55,6	293,9	30	7	3,18	3,18	9,54	22,30	1093	100,47	0,121
Bear	264-AL1/62 ST1 A	264,4	61,7	326,1	30	7	3,35	3,35	10,10	23,50	1213	111,50	0,109
Goat	324-AL1/76 ST1 A	324,3	75,7	400,0	30	7	3,71	3,71	11,10	26,00	1488	135,13	0,089
Sheep	375-AL1/88 ST1 A	375,1	87,5	462,6	30	7	3,99	3,99	12,00	27,90	1721	156,30	0,077
Antelope	374-AL1/48 ST1 A	374,1	48,5	422,6	54	7	2,97	2,97	8,91	26,70	1414	118,88	0,077
Bison	382-AL1/49 ST1 A	381,7	49,5	431,2	54	7	3,00	3,00	9,00	27,00	1443	121,30	0,075
Deer	430-AL1/100 ST1 A	429,6	100,2	529,8	30	7	4,27	4,27	12,80	29,90	1971	179,00	0,067
Zebra	429-AL1/56 ST1 A	428,9	55,6	484,5	54	7	3,18	3,18	9,54	28,60	1621	131,92	0,067
Elk	477-AL1/111 ST1 A	477,1	111,3	588,5	30	7	4,50	4,50	13,50	31,50	2190	198,80	0,060
Camel	476-AL1/62 ST1 A	476,0	61,7	537,7	54	7	3,35	3,35	10,10	30,20	1799	146,40	0,060
Moose	528-AL1/69-ST1 A	528,5	68,5	597,0	54	7	3,53	3,53	10,60	31,80	1997	159,92	0,054

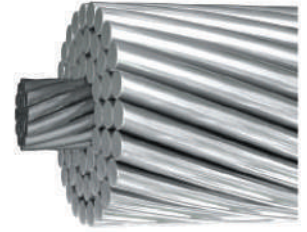

Çelik Özlü Alüminyum İletken Teknik Özellikler

Aluminium Conductors Steel Reinforced Technical Specifications

Characteristics of aluminium conductors steel reinforced used in Finland - Type AL1/ST1A

Code	Old Code	Areas			No of wires		Wire Diameter		Diameter		Mass Per Unit Length kg/km	Rated Strength kN	DC Resistance Ω/km
		Al	Steel	Total			Al	Steel	Core	Cond.			
		mm ²	mm ²	mm ²	Al	Steel	mm	mm	mm	mm			
34-AL1/6-ST1A	ACSR 34/6 SPARROW	33,8	5,6	39,5	6	1	2,68	2,68	2,68	8,04	137	12,18	0,846
54-AL1/9-ST1A	ACSR 54/9 RAVEN	53,5	8,9	62,4	6	1	3,37	3,37	3,37	10,11	216	18,64	0,535
85-AL1/14-ST1A	ACSR 85/14 PIGEON	85,1	14,2	99,3	6	1	4,25	4,25	4,25	12,75	344	29,22	0,336
106-AL1/25-ST1A	ACSR 106/25 SUURSAVO	105,9	24,7	130,6	30	7	2,12	2,12	6,36	14,84	486	47,97	0,272
152-AL1/25-ST1A	ACSR 152/25OSTRICH	152,2	24,7	176,9	26	7	2,73	2,12	6,36	17,28	614	54,78	0,189
305-AL1/39-ST1A	ACSR 305/39 DUCK	304,6	39,5	344,1	54	7	2,68	2,68	8,04	24,12	1151	96,80	0,094
565-AL1/72-ST1A	ACSR 565/72 FINCH	565,0	71,6	636,6	54	19	3,65	2,19	10,95	32,85	2123	174,14	0,051
42-AL1/25-ST1A	ACSR 42/25 SAVO	42,4	24,7	67,1	12	7	2,12	2,12	6,36	10,60	310	36,53	0,681
89-AL1/52-ST1A	ACSR 89/52 DOTTEREL	89,4	52,2	141,6	12	7	3,08	3,08	9,24	15,40	655	72,12	0,323
93-AL1/39-ST1A	ACSR 93/39 IMATRA	92,9	39,5	132,4	10	7	3,44	2,68	8,04	14,92	565	60,35	0,31
148-AL1/67-ST1A	ACSR 148/68 KUOPIO	148,3	67,1	215,3	42	19	2,12	2,12	10,60	19,08	937	105,16	0,195

NOTE: Direction of lay of external layer is right - hand (Z)

Characteristics of aluminium alloy conductors steel reinforced used in Finland - Type AL2/ST1A

Code	Old Code	Areas			No of wires		Wire Diameter		Diameter		Mass Per Unit Length kg/km	Rated Strength kN	DC Resistance Ω/km
		Al	Steel	Total			Al	Steel	Core	Cond.			
		mm ²	mm ²	mm ²	Al	Steel	mm	mm	mm	mm			
106-AL2/25-ST1A	AACSR 106/25	105,9	24,7	130,6	30	7	2,12	2,12	6,36	14,8	486	63,33	0,317

NOTE: Direction of lay of external layer is right - hand (Z)



Çelik Özlü Alüminyum İletken Teknik Özellikler

Aluminium Conductors Steel Reinforced Technical Specifications

Characteristics of aluminium conductors steel reinforced used in Sweden - Type AL1/ST1A

Code	Old Code	Areas			No of wires		Wire Diameter		Diameter		Mass Per Unit Length kg/km	Rated Strength kN	DC Resistance Ω/km
		Al	Steel	Total			Al	Steel	Core	Cond.			
		mm ²	mm ²	mm ²	Al	Steel	mm	mm	mm	mm			
54-AL1/9-ST1A	RAVEN	53,5	8,9	62,4	6	1	3,37	3,37	3,37	10,11	216	18,64	0,535
85-AL1/14-ST1A	PIGEON	85,1	14,2	99,3	6	1	4,25	4,25	4,25	12,75	344	29,22	0,336
135-AL1/22-ST1A	PARTRIDGE	134,9	22,0	156,9	26	7	2,57	2,00	6,00	16,30	545	48,66	0,214
201-AL1/33-ST1A	IBIS	201,3	32,7	234,1	26	7	3,14	2,44	7,32	19,90	812	70,53	0,143
283-AL1/146-ST1A	DOVE	282,6	45,9	328,5	26	7	3,72	2,89	8,67	23,60	1140	97,56	0,102
402-AL1/52-ST1A	CONDOR	402,3	52,2	454,5	54	7	3,08	3,08	9,24	27,70	1521	123,75	0,071
525-AL1/68-ST1A	CURLEW	525,5	68,1	593,6	54	7	3,52	3,52	10,60	31,70	1986	159,01	0,055
685-AL1/89-ST1A	SKATA	685,4	88,8	774,2	54	7	4,02	4,02	12,10	35,20	2590	207,39	0,042
806-AL1/102-ST1A	FALCON	806,2	102,4	908,7	54	19	4,36	2,62	13,10	39,30	3032	245,77	0,035
563-AL1/29-ST1A	MORKULLA	562,7	29,3	592,0	42	7	4,13	2,31	6,93	31,70	1784	123,47	0,051
735-AL1/38-ST1A	RIPA	734,9	38,0	772,9	42	7	4,72	2,63	7,89	35,20	2328	160,93	0,039
865-AL1/44-ST1A	ORRE	864,7	44,0	908,8	42	7	5,12	2,83	8,49	39,20	2733	188,55	0,033
89-AL1/52-ST1A	DOTTEREL	89,4	52,2	141,6	12	7	3,08	3,08	9,24	15,40	655	72,12	0,323
117-AL1/68-ST1A	ODEN	116,8	68,1	184,9	12	7	3,52	3,52	10,60	17,60	855	93,62	0,247
152-AL1/69-ST1A	ATLE	152,3	88,8	241,2	12	7	4,02	4,02	12,10	20,10	1115	122,10	0,189
251-AL1/65-ST1A	YMER	251,0	64,7	315,6	32	7	3,16	3,43	10,30	22,90	1200	112,56	0,115

Notes / Notlar :

- Direction of lay external layer is right - hand (Z)



Çelik Özlü Alüminyum İletken Teknik Özellikler

Aluminium Conductors Steel Reinforced Technical Specifications

Characteristics of aluminium conductors steel reinforced used in Spain- Type AL1/ST1A

Code Word Kod	New Code Yeni Kod	Section / Kesit			Composition Kompozisyon N°xØmm		Overall Diameter Çap mm		Rated Stenght Kopma Muka- vemeti kN	Electrical Resistance Direnç Ω/km	Cable Weight Birim Ağırlığı kg/km
		Al. Alum.	Çelik Steel	Toplam Total	Al. Alum.	Çelik Steel					
LA-30	27-AL1/4-ST1A	26,7	4,45	31,1	6x2,38	1x2,38	2,38	7,14	9,74	1,0736	107,8
LA-56	47-AL1/8-ST1A	46,8	7,79	54,6	6x3,15	1x3,15	3,15	9,45	16,29	0,6129	188,8
LA-78	67-AL1/11-ST1A	67,3	11,2	78,6	6x3,78	1x3,78	3,78	11,34	23,12	0,4256	271,8
LA-110	94-AL1/22-ST1A	94,2	22,0	116,2	30x2,00	7x2,00	6,00	14,0	43,17	0,3067	432,5
LA-145	119-AL1/28-ST1A	119,3	27,8	147,1	30x2,25	7x2,25	6,75	15,75	54,03	0,2423	547,4
LA-180	147-AL1/34-ST1A	147,3	34,4	181,6	30x2,50	7x2,50	7,50	17,5	64,94	0,1963	675,8
LA-280 HAWK	242-AL1/39-ST1A	241,6	39,5	281,1	26x3,44	7x2,68	8,04	21,8	84,89	0,1195	976,2
LA-380 GULL	337-AL1/44-ST1A	337,3	43,7	381,0	54x2,82	7x2,82	8,46	25,4	107,18	0,0857	1274,6
LA-455 CONDOR	402-AL1/52-ST1A	402,3	52,2	454,5	54x3,08	7x3,08	9,24	2,7	123,75	0,0719	1520,5
LA-545 CARDINAL	485-AL1/63-ST1A	484,5	62,8	547,3	54x3,38	7x3,38	10,14	30,42	149,04	0,0597	1831,1
LA-635 FINCH	565-AL1/72-ST1A	565,0	71,6	636,6	54x3,65	19x2,19	10,95	32,85	174,14	0,0512	2123,0

Notes / Notlar :

- Direction of lay external layer is right - hand (Z)



Çelik Özlü Alüminyum İletken Teknik Özellikler

Aluminium Conductors Steel Reinforced Technical Specifications

Characteristics of aluminium conductors steel reinforced used in France - Type AL1/ST1A

Code	New Code	Crosssectional Area			No of Wires		Wire Diameter		Diameter		Mass per unit length kg/km	Rated strength kN	DC resistance Ω/km	Final modulus of elasticity N/mm ²	Coefficient of linear expansion 1/K	Direction of lay of external layer
		Al	Steel	Total	Al	Steel	Al	Steel	Core	Cond						
		mm ²	mm ²	mm ²												
CANNA 37,7	28-AL1/9-ST1A	28,3	9,42	37,7	9	3	2,00	2,00	4,30	8,3	152	16,26	1,018 7	88000	1,71E-5	S
CANNA 59,7	38-AL1/22-ST1A	37,7	22,0	59,7	12	7	2,00	2,00	6,00	10,0	276	32,70	0,766 0	103500	1,54E-5	S
CANNA 75,5	48-AL1/28-ST1A	47,7	27,8	75,5	12	7	2,25	2,25	6,75	11,3	349	41,15	0,605 2	103500	1,54E-5	S
CANNA 93,3	59-AL1/34-ST1A	58,9	34,4	93,3	12	7	2,50	2,50	7,50	12,5	431	49,48	0,490 2	103500	1,54E-5	Z
CANNA 116,2	94-AL1/22-ST1A	94,2	22,0	116,2	30	7	2,00	2,00	6,00	14,0	433	43,17	0,306 7	75500	1,80E-5	S
CANNA 147,1	119-AL1/28-ST1A	119,3	27,8	147,1	30	7	2,25	2,25	6,75	15,8	547	54,03	0,242 3	75500	1,80E-5	S
CANNA 181,6	147-AL1/34-ST1A	147,3	34,4	181,6	30	7	2,50	2,50	7,50	17,5	676	64,94	0,196 3	75500	1,80E-5	S
CANNA 228	185-AL1/43-ST1A	184,7	43,1	227,8	30	7	2,80	2,80	8,40	19,6	848	80,54	0,156 5	75500	1,80E-5	S
CANNA 288	234-AL1/55-ST1A	233,8	54,6	288,3	30	7	3,15	3,15	9,45	22,1	1073	98,58	0,123 6	75500	1,80E-5	S

Kod Code	Kesit Section			Kompozisyon N°xØmm		Çap mm Overall Diameter		Tensile S _b ibar. Steel	Kopma Mukavemeti N Rated Stenght	Direnç Ω/km Electrical Resistance	Birim Ağırlığı Kg/km Cable Weight			Grease Weight g/m	
	Al. Alum.	Çelik Steel	Toplam Total	Al Alum.	Çelik Steel	Çelik Öz Care	Toplam Total				Al Alum.	Çelik Steel	Toplam Total	Outside layer greased	Outside layer ungreased
CROCUS 297	221,7	75,5	297,2	36x2,80	19x2,25	11,3	156,8	156,8	14,7	0,131	594	624	1218	35	20
CROCUS 412	325,7	86,0	411,7	32x3,60	19x2,40	12,0	156,8	156,8	17,3	0,090	676	917	1593	50	25
CROCUS 612	507,8	104,7	611,8	66x3,13	19x2,65	13,3	156,8	156,8	23,2	0,057	824	1	2241	70	40
CROCUS 865	717,3	148,1	865,4	66x3,72	19x3,15	15,8	156,8	156,8	31,9	0,041	1164	2010	3174	100	55
CROCUS 1185	956,7	227,8	1184,5	54x2,80 + 66x3,47	37x2,80	19,6	44,7	156,8	48,1	0,030	1796	2682	4478	140	100



Çelik Özlü Alüminyum İletken Teknik Özellikler

Aluminium Conductors Steel Reinforced Technical Specifications

Characteristics of aluminium conductors steel reinforced used in Russia - Type AS/ASK

Номи- нальное сечение, mm ²	Алюминиевая часть провода		Стальной сердечник		Число повивов		Отношение сечения алюминиевой части провода к сечению стального сердечника
	число проволок	номинальный диаметр проволок, мм	число проволок	номинальный диаметр проволок, мм	алюминиевых проволок	стальных проволок	
10/1,8	6	1,50	1	1,50	1	-	6,00
16/2,7	6	1,85	1	1,85	1	-	6,00
25/4,2	6	2,30	1	2,30	1	-	6,00
35/6,2	6	2,80	1	2,80	1	-	6,00
50/8,0	6	3,20	1	3,20	1	-	6,00
70/11	6	3,80	1	3,80	1	-	6,00
70/72	18	2,20	19	2,20	1	2	0,95
95/16	6	4,50	1	4,50	1	-	6,00
95/141	24	2,20	37	2,20	1	3	0,65
120/19	26	2,40	7	1,85	2	1	6,25
120/27	30	2,20	7	2,20	2	1	4,29
150/19	24	2,80	7	1,85	2	1	7,85
150/24	26	2,70	7	2,10	2	1	6,14
150/34	30	2,50	7	2,50	2	1	4,29
185/24	24	3,15	7	2,10	2	1	7,71
185/29	26	2,98	7	2,30	2	1	6,24
185/43	30	2,80	7	2,80	2	1	4,29
185/128	54	2,10	37	2,10	2	3	1,46
205/27	24	3,30	7	2,20	2	1	7,71
240/32	24	3,60	7	2,40	2	1	7,71
240/39	26	3,40	7	2,65	2	1	6,11
240/56	30	3,20	7	3,20	2	1	4,29
300/39	24	4,00	7	2,65	2	1	7,81
300/48	26	3,80	7	2,95	2	1	6,16
300/66	30	3,50	19	2,10	2	2	4,39
300/67	30	3,50	7	3,50	2	1	4,29
300/204	54	2,65	37	2,65	2	3	1,46
3320/30	48	2,98	7	2,30	3	1	11,55
330/43	54	2,80	7	2,80	3	1	7,71
400/18	42	3,40	7	1,85	3	1	20,27
400/22	76	2,57	7	2,00	4	1	17,93
400/51	54	3,05	7	3,05	3	1	7,71
400/64	26	4,37	7	3,40	2	1	6,14



Çelik Özlü Alüminyum İletken Teknik Özellikler

Aluminium Conductors Steel Reinforced Technical Specifications

Aluminium Conductor Steel Reinforced Technical Specifications

Номи- нальное сечение, мм ²	Алюминиевая часть провода		Стальной сердечник		Число повивов		Отношение сечения алюминиевой части провода к сечению стального сердечника
	число проволок	номинальный диаметр проволок, мм	число проволок	номинальный диаметр проволок, мм	алюминиевых проволок	стальных проволок	
400/93	30	4,15	19	2,50	2	2	4,35
450/56	54	3,20	7	3,20	3	1	7,71
500/26	42	3,90	7	2,20	3	1	18,86
500/27	76	2,84	7	2,20	4	1	18,09
500/64	54	3,40	7	3,40	3	1	7,71
500/204	90	2,65	37	2,65	3	3	2,43
500/36	54	3,40	61	2,65	2	4	1,46
550/71	54	3,60	7	3,60	3	1	7,71
600/72	54	3,70	19	2,20	3	2	8,04

Alüminyum Kaplı Çelik Özlü Alüminyum İletken Teknik Özellikler

Aluminium Clad Steel Reinforced Aluminium Conductors Technical Specifications

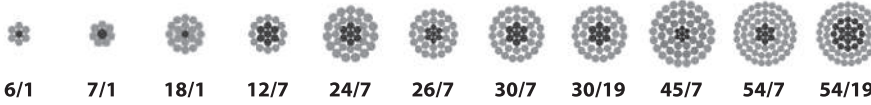

ACSR/AW Alüminyum Kaplı Çelik Özlü Alüminyum İletkenler

Genel Bilgi

ACSR/AW iletkenler birden çok alüminyum ve alüminyum kaplı çelik tellerin merkezde olacak şekilde birbiri üzerine bükülmesi ile üretilir. Alüminyum kaplı çelik teller merkezde bükülü olarak bulunur ve 1, 7, 19 veya 37 telden oluşur. Alüminyum kaplı çelik tel ve alüminyum tellerin dış çapları çoğunlukla aynıdır ancak alüminyum kaplı çelik tel ve alüminyum tel çapları farklılık arz edebilir. Alüminyum kaplı çelik özlü iletken için taşıyıcı fonksiyonda olmasıdır.

Alüminyum kaplı çelik tellerin, galvaniz kaplı çelik tellere göre önemli avantajları vardır :

- Daha yüksek korozyon dayanımı
- Daha yüksek akım taşıma kapasitesi

Özellikle korozyif atmosfer şartlarının bulunduğu sahalarda çalışacak elektrik iletim hatlarında ACSR/AW iletkenlerin kullanılması tavsiye edilmektedir.

Kullanım Alanları

- Trafo Merkezleri , • Elektrik Dağıtım Hatları, • Elektrik İletim hatları

ACSR/AW Aluminium Conductor Aluminium Clad Steel Reinforced

General Information

ACSR/AW conductors are composed of several aluminum and aluminum clad steel wires. Aluminum clad steel wires are always central and aluminum wires stranded over aluminum clad steel wire strands. Aluminum clad steel wires are aluminum clad and mostly composed of 1, 7, 19 or 37 wires. Wire outer diameters of aluminum clad steel and aluminium will be same or different but all steel wires have same diameter as well aluminium wires have same diameter. Function of aluminum clad steel wires is suspension of conductor on the line.

Aluminium clad steel wire has important advantages against galvanized steel wire:

- Higher corrosion resistance
- Higher ampacity

These conductors should be used in such places where transmission line has to be constructed in high atmospheric corrosion and air pollution.

Applications

- Substations, • Electricity Distribution Lines, • Electricity Transmission Lines

ALUMINIUM CONDUCTORS - ALUMINIUM CLAD STEEL REINFORCED

CODE NUMBER	CROSS SECTION			Cu Equiv.	STRANDING & WIRE DIAM.		OVERALL DIAMETER	UNIT WEIGHT			RATED STRENGTH	ELECTRICAL RESISTANCE AT 20°C	
	mm ²	mm ²	mm ²		mm ²	No x mm		No x mm	kg/km	kg/km			kg/km
	Aluminium	AV	Total		mm ²	Aluminium		Steel	Aluminium	AV			Total
LARL-30	26,7	4,4	31,1	18	6X2,38	1X2,38	7,14	73	29	103	10,2	1,018	
LARL-56	46,8	7,8	54,6	30	6X3,15	1X3,15	9,45	128	51	180	7,2	0,581	
LARL-78	67,4	11,2	78,6	44	6X3,78	1X3,78	11,34	185	74	259	23,0	0,403	
LARL-145	119,3	27,8	147,1	78	30X2,25	7X2,25	15,75	330	184	514	55,1	0,224	
LARL-180	147,3	34,3	181,6	97	20X2,50	7X2,50	17,50	407	227	634	66,3	0,182	
LARL-280	241,7	39,4	281,1	157	26X3,44	7X2,68	21,80	667	262	929	87,6	0,113	
LARL-380	337,3	43,7	381,0	217	54X2,82	7X2,82	25,38	932	290	1222	109,6	0,082	
LARL-455	402,3	52,2	454,4	259	54X3,08	7X3,08	27,72	1112	345	1457	129,4	0,069	
LARL-516	483,4	33,4	516,8	311	45X3,70	7X2,47	29,61	1339	221	1560	117,4	0,059	
LARL-545	484,5	62,8	547,3	312	54X3,38	7X3,38	30,42	1339	416	1755	153,2	0,057	
LARL-635	565,0	71,6	636,6	364	54X3,65	19X2,19	32,85	1562	475	2037	177,5	0,490	

Notes / Notlar :

- ACS : Aluminium clad steel

ASTM B-232 (IEC 61089)



Alüminyum Kaplı Çelik Özlü Alüminyum İletken Teknik Özellikler

Aluminium Clad Steel Reinforced Aluminium Conductors Technical Specifications

ALUMINIUM CONDUCTORS - ALUMINIUM CLAD STEEL REINFORCED A1/SA1A IEC 61089 STANDARD

CODE NUMBER	STEEL RATIO	CROSS SECTION			STRANDING & WIRE DIAM.		OVERALL DIAMETER	UNIT WEIGHT	RATED STRENGTH	ELECTRICAL RESISTANCE AT 20°C
	%	mm ²	mm ²	mm ²	No x mm	No x mm	mm	kg/km	kN	ohm/km
		Aluminium	SA1A	Total	Aluminium	SA1A		Total		
16	16,7	15	2,56	17,6	6X1,81	1X1,81	5,43	59,0	5,91	1,792
25	16,7	24	4,00	28,0	6X2,26	1X2,26	6,78	92,1	9,00	1,147
40	16,7	38	6,40	44,4	6X2,85	1X2,85	8,55	147,4	14,21	0,717
63	16,7	60	10,08	70,1	6X3,58	1X3,58	10,70	232,2	21,17	0,455
100	16,7	96	16,00	112,0	6X4,51	1X4,51	13,50	368,6	31,84	0,287
125	5,6	123	6,85	130,0	18X2,95	1X2,95	14,80	384,3	29,18	0,230
125	16,3	120	19,60	140,0	26X2,43	7X1,89	15,40	460,8	44,49	0,231
160	5,6	158	8,77	167,0	18X3,34	1X3,34	16,70	491,9	36,38	0,180
160	16,3	154	25,00	179,0	26X2,74	7X2,13	17,40	589,8	56,18	0,180
200	5,6	197	10,96	208,0	18X3,74	1X3,74	18,70	614,9	43,62	0,144
200	16,3	192	31,30	223,0	26X3,07	7X2,39	19,40	737,2	69,27	0,144
250	9,8	244	24,00	268,0	32X3,76	7X2,09	21,30	830,9	67,80	0,115
250	16,3	240	39,10	279,0	26X3,43	7X2,67	21,70	921,5	86,58	0,115
315	6,9	310	21,40	331,0	45X2,96	7X1,97	23,70	996,4	78,33	0,092
315	16,3	303	49,30	352,0	26X3,75	7X2,99	24,40	1161,1	107,58	0,092
400	6,9	393	27,20	420,0	45X3,34	7X2,22	26,70	1265,3	97,50	0,072
400	13,0	387	50,20	437,0	54X3,02	7X3,02	27,20	1402,9	124,20	0,072
450	6,9	442	40,60	483,0	45X3,54	7X2,36	28,30	1423,4	107,48	0,064
450	13,0	436	56,50	493,0	54X3,21	7X3,21	28,90	1578,2	139,72	0,064
500	6,9	492	34,00	526,0	45X3,73	7X2,49	29,80	1581,6	119,42	0,058
500	13,0	484	62,80	547,0	54X3,78	7X3,38	30,40	1753,6	153,99	0,058
560	6,9	550	38,10	588,0	45X3,95	7X2,63	31,60	1771,4	133,75	0,052
560	12,7	543	68,80	612,0	54X3,58	19X2,15	32,20	1956,3	169,36	0,052
630	6,9	619	42,80	662,0	45X4,19	7X2,79	33,50	1992,8	150,47	0,046
630	12,7	611	77,30	688,0	54X3,79	19X2,28	34,20	2200,9	190,52	0,046
710	6,9	698	48,30	746,0	45X4,44	7X2,96	35,60	2245,8	169,57	0,041
710	12,7	688	87,20	775,0	54X4,03	19X2,42	36,30	2480,3	214,72	0,041
800	4,3	791	34,20	825,0	72X3,74	7X2,49	37,40	2412,8	167,67	0,036
800	8,3	784	65,30	849,0	84X3,45	7X3,45	37,90	2598,9	206,37	0,036
800	12,7	775	98,20	873,0	54X4,28	19X2,57	38,50	2794,7	241,94	0,036
900	4,3	890	38,50	929,0	72X3,97	7X2,65	39,70	2714,4	188,63	0,032
900	8,3	882	73,50	956,0	84X3,66	7X3,66	40,20	2923,8	224,82	0,032
1000	4,3	989	42,70	1032,0	72X4,18	7X2,79	41,80	3016,0	209,59	0,029
1120	8,1	1098	89,40	1187,0	84X4,08	19X2,45	44,90	3628,4	282,88	0,026
1250	8,1	1225	99,80	1325,0	84X4,31	19X2,59	47,40	4049,5	315,72	0,023

Alüminyum Kaplı Çelik Özlü Alüminyum İletken Teknik Özellikler

Aluminium Clad Steel Reinforced Aluminium Conductors Technical Specifications

ALUMINIUM CONDUCTORS - ALUMINIUM CLAD STEEL REINFORCED ASTM B 549 STANDARD

CODE WORD	CROSS SECTION			STRANDING & WIRE DIAM.		OVERALL DIAMETER	UNIT WEIGHT	RATED STRENGTH	ELECTRICAL RESISTANCE AT 20°C	
	AWG o Kemils mm ²	mm ²	mm ²	No x mm	No x mm					
	Aluminium	AW	Total	Aluminium	AW					
SWAN	4,0	21,2	3,53	24,7	6x2,12	1x2,12	6,36	81	7,9	1,282
SWANATE	4,0	21,1	5,35	26,5	7x1,96	1x2,61	6,53	93	10,1	1,251
SPARROW	2,0	33,6	5,60	39,2	6x2,67	1x2,67	8,01	129	12,3	0,808
SPARATE	2,0	33,5	8,55	42,1	7x2,47	1x3,30	8,24	149	15,6	0,787
ROBIN	1,0	42,4	7,07	49,5	6x3,00	1x3,00	9,00	163	15,3	0,640
RAVEN	1/0	53,5	8,92	62,4	6x3,37	1x3,37	10,11	205	18,9	0,507
QUAIL	2/0	67,3	11,22	78,6	6x3,78	1x3,78	11,34	259	22,8	0,403
PIGEON	3/0	85,1	14,19	99,3	6x4,25	1x4,25	12,75	326	28,0	0,319
PENGUIN	4/0	107,2	17,87	125,1	6x4,77	1x4,77	14,31	411	34,2	0,253
WAXWING	266,8	135,0	7,50	142,5	18x3,09	1x3,09	15,45	421	30,3	0,210
PARTRIDGE	266,8	134,9	21,99	156,9	26x2,57	7x2,00	16,28	520	48,0	0,204
OSTRICH	300,0	152,2	24,71	176,9	26x2,73	7x2,12	17,28	584	54,0	0,180
MERLIN	336,4	170,2	9,46	179,7	18x3,47	1x3,47	17,35	532	38,0	0,166
LINNET	336,4	170,6	27,83	198,4	26x2,89	7x2,25	18,31	654	60,0	0,161
ORIOLE	336,4	170,5	39,78	210,3	30x2,69	7x2,69	18,83	736	74,5	0,158
CHICKADEE	397,5	200,9	11,16	212,1	18x3,77	1x3,77	18,85	628	43,5	0,141
BRANT	397,5	201,6	26,13	227,7	24x3,27	7x2,18	19,62	730	62,5	0,138
IBIS	397,5	201,3	32,73	234,1	26x3,14	7x2,44	19,88	773	70,2	0,136
LARK	397,5	200,9	46,88	247,8	30x2,92	7x2,92	20,44	869	87,3	0,134
PELİCAN	477,0	242,3	13,46	255,8	18x4,14	1x4,14	20,70	754	51,0	0,117
FLICKER	477,0	241,6	31,40	273,0	24x3,58	7x2,39	21,49	876	74,3	0,115
HAWK	477,0	241,7	39,19	280,8	26x3,44	7x2,67	21,77	928	84,3	0,114
HEN	477,0	241,3	56,30	297,6	30x3,20	7x3,20	22,40	1043	104,0	0,112
OSPREY	556,5	282,5	15,69	298,2	18x4,47	1x4,47	22,35	879	58,9	0,100
PARAKEET	556,5	282,3	36,60	318,9	24x3,87	7x2,58	23,22	1022	85,7	0,098
DOVE	556,5	282,6	45,92	328,5	26x3,72	7x2,89	23,55	1084	97,5	0,097
EAGLE	556,5	282,1	65,82	347,9	30x3,46	7x3,46	24,22	1217	119,0	0,095
PEACOCK	605,0	306,1	39,78	345,9	24x4,03	7x2,69	24,19	1111	93,3	0,091
SQUAB	605,0	305,8	49,81	355,6	26x3,87	7x3,01	24,51	1178	105,0	0,090
WOOD DUCK	605,0	307,1	71,65	378,7	30x3,61	7x3,61	25,27	1323	126,0	0,088
TEAL	605,0	307,1	69,62	376,7	30x3,61	19x2,16	25,24	1313	126,6	0,088
KINGBIRD	636,0	323,0	17,95	341,0	18x4,78	1x4,78	23,90	1005	66,8	0,088
ROOK	636,0	323,1	41,88	365,0	24x4,14	7x2,76	24,84	1168	98,0	0,086
GROSBEAK	636,0	321,8	52,49	374,3	26x3,97	7x3,09	25,15	1238	110,0	0,085
SCOTER	636,0	322,6	75,26	397,8	30x3,70	7x3,70	25,90	1391	130,0	0,083
EGRET	636,0	322,6	73,54	396,1	30x3,70	19x2,22	25,90	1381	133,0	0,084
SWIFT	636,0	323,0	8,97	332,0	36x3,38	1x3,38	23,66	946	60,6	0,088
FLAMİNGO	666,6	337,3	43,72	381,0	24x4,23	7x2,82	25,38	1224	103,0	0,082
GANNET	666,6	338,3	54,90	393,2	26x4,07	7x3,16	25,76	1298	116,0	0,081
STILT	715,5	363,3	46,88	410,1	24x4,39	7x2,92	26,32	1314	110,0	0,076
STARLING	715,5	361,9	59,15	421,1	26x4,21	7x3,28	26,68	1393	122,0	0,076
REDWING	715,5	362,1	82,41	444,5	30x3,92	19x2,35	27,43	1552	148,0	0,074
TERN	795,0	403,8	27,83	431,6	45x3,38	7x2,25	27,03	1298	95,4	0,070
CONDOR	795,0	402,3	52,15	454,5	54x3,08	7x3,08	27,72	1459	124,0	0,069
CUCKOO	795,0	402,3	52,15	454,5	24x4,62	7x3,08	27,74	1459	122,0	0,069
DRAKE	795,0	402,6	65,44	468,0	26x4,44	7x3,45	28,11	1549	136,0	0,068
COOT	795,0	401,9	11,16	413,0	36x3,77	1x3,77	26,41	1182	73,8	0,071
MALLARD	795,0	403,8	91,78	495,6	30x4,14	19x2,48	28,96	1726	165,0	0,067
RUDDY	900,0	455,5	31,67	487,2	45x3,59	7x2,40	28,73	1470	107,0	0,062
CANARY	900,0	456,3	59,15	515,4	54x3,28	7x3,28	29,52	1653	138,0	0,061
RAIL	954,0	483,8	33,54	517,4	45x3,70	7x2,47	29,61	1558	113,0	0,059
CATBIRD	954,0	484,6	13,46	498,1	36x4,14	1x4,14	28,95	1419	86,6	0,059
CARDINAL	954,0	484,5	62,81	547,3	54x3,38	7x3,38	30,42	1751	146,0	0,057
ORTLAN	1,033,5	523,9	36,31	560,2	45x3,85	7x2,57	30,81	1687	121,0	0,054
TANAGER	1,033,5	522,8	14,52	537,3	36x4,30	1x4,30	30,12	1537	93,7	0,055
CURLEW	1,033,5	525,5	68,12	593,6	54x3,52	7x3,52	31,68	1896	158,0	0,053
BLUEJAY	1,113,0	565,5	38,90	604,4	45x4,00	7x2,66	31,98	1819	121,0	0,050
FINCH	1,113,0	565,0	71,57	636,6	54x3,65	19x2,19	32,85	2043	167,0	0,049

EN 50182 (ASTM B 549)



Alüminyum Kaplı Çelik Özlü Alüminyum İletken Teknik Özellikler

Aluminium Clad Steel Reinforced Aluminium Conductors Technical Specifications

ALUMINIUM CONDUCTORS - ALUMINIUM CLAD STEEL REINFORCED

ASTM B 549 STANDARD

HIGH MECHANICAL STRENGTH

CODE WORD	CROSS SECTION			STRANDING & WIRE DIAM.		OVERALL DIAMETER	UNIT WEIGHT	RATED STRENGTH	ELECTRICAL RESISTANCE AT 20°C	
	AWG o Kemils mm ²	mm ²	mm ²	No x mm	No x mm					
	Aluminium	AW	Total	Aluminium	AW					
BUNTING	1192,5	605,8	41,9	647,6	45x4,14	7x2,76	33,12	1948	139,0	0,047
CRACKLE	1192,5	602,8	76,9	679,7	54x3,77	19x2,27	33,97	2187	179,0	0,046
BITTERN	1272,0	644,4	44,7	689,1	45x4,27	7x2,85	34,17	2077	149,0	0,044
PHEASANT	1272,0	645,4	81,7	726,8	54x3,90	19x2,34	35,10	2333	189,0	0,043
SKYLARK	1272,0	645,0	18,0	664,0	36x4,78	1x4,78	33,42	1893	114,0	0,044
DIPPER	1351,5	684,2	46,9	731,1	45x4,40	7x2,92	35,16	2207	158,0	0,041
MARTIN	1351,5	685,4	86,7	772,1	54x4,02	19x2,41	36,17	2478	200,0	0,041
BOBOLINK	1431,0	725,3	50,1	775,4	45x4,53	7x3,02	36,24	2337	167,0	0,039
PLOVER	1431,0	726,9	91,8	818,7	54x4,14	19x2,48	37,24	2625	212,0	0,038
NUTHACH	1510,5	764,2	52,8	817,0	45x4,65	7x3,10	37,20	2467	176,0	0,037
PARROT	1510,5	766,1	97,0	863,1	54x4,25	19x2,55	38,25	2788	224,0	0,036
LAPWING	1590,0	804,2	55,6	859,7	45x4,77	7x3,18	38,16	2598	186,0	0,035
FALCON	1590,0	806,2	102,4	908,7	54x4,36	19x2,62	39,26	2917	236,0	0,035
CHUKAR	1780,0	903,2	73,5	976,7	84x3,70	19x2,22	42,70	2995	220,0	0,031
BLUEBIRD	2156,0	1092,8	88,8	1181,6	84x4,07	19x2,44	44,76	3626	262,0	0,026
KIWI	2167,0	1099,8	47,5	1147,3	72x4,41	7x2,94	44,10	3367	219,0	0,026
THRASHER	2312,0	1171,4	63,9	1235,3	76x4,43	19x2,07	45,79	3678	246,0	0,024
GROUSE	80,0	40,5	14,3	54,8	8X2,54	1X4,24	9,32	205	21,7	0,635
PETREL	101,8	51,6	30,1	81,7	12X2,34	7X2,24	11,71	342	44,1	0,469
MINORCA	110,8	56,1	32,8	88,9	12X2,44	7X2,44	12,22	372	48,0	0,431
LEGHORN	134,6	68,2	39,8	108,0	12X2,69	7X2,69	13,46	452	57,8	0,354
GUINEA	159,0	80,6	47,0	127,6	12X2,92	7X2,92	14,63	534	68,0	0,300
DOTTEREL	176,9	89,5	52,2	141,7	12X3,08	7X3,08	15,42	594	75,4	0,270
DORKING	190,8	96,7	56,4	153,1	12X3,20	7X3,20	16,03	641	81,3	0,250
BRAHMA	203,2	103,0	91,9	194,8	16X2,86	19X2,48	18,14	894	120,0	0,216
COCHIN	211,8	107,1	62,5	169,6	12X3,37	7X3,37	16,84	709	88,0	0,226

GALVANİZLİ ÇELİK TELLERDEN İMAL EDİLMİŞ TOPRAK TELLERİ

EARTH WIRE WITH GALVANIZED STEEL STRAND

(GALVANIZED EARTH WIRE) GALVANİZLİ TOPRAK TELİ	70 mm ²	96 mm ²
Diameter of Complex Conductor / Komple İletkenin Çapı (mm)	11,05 mm	12,70 mm
Steel Wire Diameter / Çelik Telin Çapı (mm)	2,21 mm	2,54 mm
Total cross section of steel / Çeliğin Toplam Kesit Alanı (mm ²)	72 mm ²	96 mm ²
Total cross-sectional area of the conductor / İletkenin Toplam Kesit Alanı (mm ²)	72,88 mm ²	96,27 mm ²
Unit weight / Çeliğin birim ağırlığı (kg/km)	580 kg/km	759 kg/km
Rated Breaking Force / Anma Kopma Kuvveti (kg)	9435	12212
Steel Final Elasticity Module / Çeliğin Nihai Elastisite Modülü (kg/mm ²)	19.000 kg/mm ²	19.000 kg/mm ²
Steel Heat elongation Coefficient / Çeliğin Isı Uzama Katsayısı (1/°Cx10-6)	11,5 (1/°Cx10-6)	11,5 (1/°Cx10-6)
Number of Wire in Conductor Layers / İletken Katmanlarındaki Tel Sayısı	1+6+12	1+6+12
Minimum breaking length at 250 mm before steel wire mesh / Çelik tellerin örgüden önce 250 mm'de olarak minimum kopma uzaması	4	4
Zinc Coating Type and Thickness / Çinko Kaplamanın Tipi ve Kalınlığı	214 gr/mm ²	229 gr/mm ²
Step rate / Adım oranı	10-16	10-16
Wind pressure / Rüzgar basıncı (kg/m ²)	70 kg/m ²	70 kg/m ²
Highest solar radiation / En yüksek güneş ışınımı (W/m ²)	1000 W/m ²	1000 W/m ²



www.araskablo.com



info@araskablo.com